

PRESTAZIONI E CARATTERISTICHE

| POMPA <i>PUMP TYPE</i> | GIRANTE TIPO <i>IMPELLER TYPE</i> | CURVE <i>CURVES</i> | min 1° <i>RPM</i> | PAG. <i>PAGE</i> |
|----------------------------------|---|---|-----------------------------|----------------------------|
| COMPATTA | VORTEX | 2-3-4-5-6 | 2850 | 7 - 11 |
| VM-VT | VORTEX | 346-347354-357-367-368 | 2850 | 12 - 17 |
| VM-VT | VORTEX | 341-342-343-344-345-349-350355-356360-362-363-375-380-385-390-395 | 1450 | 18 - 31 |
| GM-GT | TRITURATORE <i>GRINDER</i> | 149-150-155-160-165-170175-180 | 2850 | 32 - 39 |
| AM-AT | BICANALE APERTA <i>TWIN OPEN</i> | 218-219-225-226 | 2850 | 40 - 43 |
| AM- AT | MONOCANALE APERTA <i>SINGLE CHANNEL OPEN</i> | 236-237-247-257-267-268 | 2850 | 44 - 51 |
| AM-AT | MONOCANALE APERTA <i>SINGLE CHANNEL OPEN</i> | 241-242-243-244-245-255-256173 | 1450 | 52 - 61 |
| AM-AT | MONOCANALE CHIUSA <i>SINGLE CHANNEL CLOSED</i> | 264-265-275-280-285-290-295 | 1450 | 62 - 69 |

INFORMAZIONI

| | |
|------------------------|----------------|
| INTRODUZIONE | 2 - 3 |
| SELEZIONE GIRANTI | 4 |
| CAMPI DI SCELTA | 5 |
| STAZIONE DI POMPAGGIO | 70 |
| ACCESSORI | 71 - 73 |
| SCHEMA D'INSTALLAZIONE | 74 |
| ALLEGATI TECNICI | 75 - 76 |

IMPIEGHI ELETTROPOMPE SOMMERGIBILI da DN 32 a DN 150

Le nostre elettropompe sommergibili, per la loro robusta costruzione, possono essere impiegate per il convogliamento di diversi tipi di liquidi, fra i quali :
acque pulite, acque potabili, acque piovane, acque miste, acque grezze, acque nere contenenti solidi e fibre, fanghi ravnivati, fanghi grezzi, fanghi putridi e miscugli di acque.

TEMPERATURA E CARATTERISTICHE LIQUIDO**Temperatura massima del liquido da pompare:**

+ 40 °C con unità completamente sommersa (Sono disponibili versioni speciali per pompare liquidi fino a +60 °C)

Massima profondità di immersione:

20m

Minima profondità di immersione:

Vedi indicazione quota sulle schede tecniche

Valori pH ammessi:

da pH 6 a pH 10

Le caratteristiche idrauliche valgono per liquidi con densità < 1,1 Kg/dm³.

Il liquido da pompare può contenere parti solide fino al diametro di passaggio consentito dal disegno della girante.

MATERIALI

- Cassa motore, Corpo pompa, Girante: G G 25
- Viteria: AISI 304
- Albero Motore: AISI 420
- Anelli O'Ring: gomma nitrilica NBR 70

MOTORI**Monofase:**

Motore asincrono a 2 e 4 poli con rotore a gabbia di scoiattolo.

Isolamento Statore: Classe F = 155 °C, Grado Protezione: IP 68
In tutti i modelli Monofase il condensatore è inserito sotto il coperchio motore (esclusi i modelli che sono forniti con quadretto a parte) e sono dotati di protezione termica inserita nell'avvolgimento che assicura un tempestivo arresto del motore in caso di elevata temperatura.

Il raffreddamento è effettuato dal liquido nel quale è immerso, la cassa del motore è progettata per una buona dissipazione termica.

Trifase:

Motore elettrico di tipo asincrono a 2 e 4 Poli con rotore a gabbia di scoiattolo.

Isolamento Statore: Classe F = 155 °C, Grado Protezione: IP 68
Protezione motore a carico dell' utente.

Le elettropompe sono dotate di sensori termici nell'avvolgimento che provvedono alla segnalazione tempestiva o allo spegnimento della pompa in caso di sovratemperature del motore. Le pompe possono riprendere a funzionare automaticamente a raffreddamento avvenuto.

ATTENZIONE!

E' molto importante che i sensori termici siano collegati correttamente al quadro di comando installato.

Le elettropompe sono inoltre dotate di sensore che rileva tempestivamente eventuali infiltrazioni di liquido attraverso gli organi di tenuta.

Il raffreddamento è effettuato dal liquido nel quale è immersa, la cassa del motore è progettata per una buona dissipazione termica anche in caso di impieghi gravosi. E' consentito un massimo di 15 Avviamenti/Ora, distanziati regolarmente.

APPLICATIONS SUBMERSIBLE ELECTRIC MOTOR PUMPS from DN 32 up to DN 150

Our submersible electric motor pumps, thanks to their heavy built construction, are suitable for several types of liquids, among which we would like to point out: clean water, drinking water, rain water, mixed water, raw water, waste water containing solids and fibres, stirred sludge, raw sludge, putrid sludge, sewage and mixtures of water.

LIQUID TEMPERATURE AND CHARACTERISTICS**Maximum temperature of pumped liquid:**

+ 40 °C with the pump completely submerged (Special versions are available for pumping liquids up 60 °C)

Maximum submersion depth:

20 m

Minimum submersion depth:

consult statements on pump charts

pH-value of pumped liquid:

between 6 to 10

The given hydraulic performanes are valid for liquids:

with densities lower as 1,1 kg/dm³.

Pumped liquids may contain suspended solid particles up to the diameters allowed by the impeller design.

MATERIALS

- Motor casing, Body pump, Impeller: G G 25
- Bolts: AISI 304
- Motor Shaft: AISI 420
- O'Rings: NBR 70

MOTORS**Single phase :**

Asynchronous electric 2 or 4 pole motors with squirrel-cage rotors.

Stator Insulation : F =155 °C, Protection class : IP 68

All single phase motors are equipped with built in capacitors (except the models supplied with separate connection box) and are equipped with thermal overload protections built in to the motor windings to assure an immediate net supply cut off in case of too high temperatures. The motor cooling is provided by the liquid the pump is submerged, the motor casing has been designed for high temperature dissipation.

Three phase:

Asynchronous electric 2 or 4 poles motors with squirrel-cage rotors.

Insulation class : F =155 °C, Protection class : IP 68

The thermal overload must be provided by the installer. The electropumps are fitted with thermal sensors in the stator, which give a warning or switch off the unit in the event of excessive temperatures arising in the motor. The pumps may switch itself automatically back on after it has cooled down.

ATTENTION!

The thermal sensors must be correctly connected into the installed control panel.

In addition our electropumps are fitted with an electrode, which give signal that an inspection is due in the case of leakage at the shaft seal.

The motor cooling is provided by the liquid the pump is submerged, the motor casing has been designed for high temperature dissipation and is suitable for heavy operations.

Motors are built for maximum 15 Starts / Hours, duly separated.

TENSIONI DI ALIMENTAZIONE :

Monofase: Volt 230 ($\pm 5\%$) 50 Hz

Trifase : Volt 400 ($\pm 5\%$) 50 Hz

Altre tensioni: Su richiesta

Massimo squilibrio ammesso sulla corrente assorbita: $\pm 5\%$

La dotazione di serie comprende 10 mt di cavo H07RNF con terminali liberi (Spina Schuko per le versioni 1~ 230V/50Hz)

Senso di rotazione : orario visto dall'alto

Il livello max di rumorosità di tutte le nostre pompe è 70 dB(A).
A volte, in funzione del tipo di installazione e del punto di lavoro richiesto è possibile raggiungere tale livello max.

P1 = Potenza assorbita dalla rete P2 = Potenza resa del motore

ALBERO MOTORE e CUSCINETTI:

Il lato girante dell'albero motore è costruito in acciaio inossidabile AISI 420.

L'albero motore è supportato da cuscinetti lubrificati a vita ed esenti da manutenzione (SKF o equivalente).

TENUTE MECCANICHE

La tenuta sull'albero motore, a protezione del motore elettrico, viene garantita da due tenute meccaniche sistemate in tandem (BURGMANN o equivalente), indipendenti dal senso di rotazione, con superfici di scorrimento in sil./sil. in camera d'olio ecologico. Nei casi di avaria della prima tenuta meccanica, la seconda garantisce il funzionamento sicuro dell'elettropompa.

- Tenute lato motore :

COMPATTA , serie AM 32 e AM 40 :

Tenute radiali di alta qualità su motore 125/152/173 :

Ceramica / Grafite, resistente all'usura su motore 200/240/340:

Carburo di Silicio+Viton, altamente resistente all'usura

- Tenute lato girante :

per tutte le versioni: Carburo di Silicio+Viton, altamente resistente all'usura

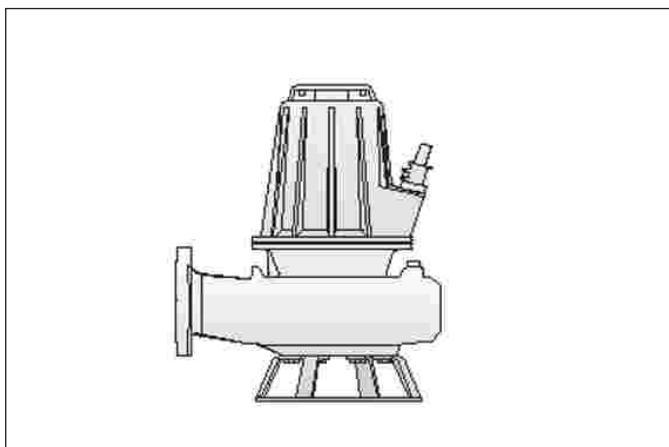
**INSTALLAZIONE MOBILE
MOBILE INSTALLATION**

NET SUPPLY TENSIONS:

Single phase : Volt 230 ($\pm 5\%$) 50 Hz

Three phase : Volt 400 ($\pm 5\%$) 50 Hz

Different Tensions: On request

Max. power draw unbalance: $\pm 5\%$

10m net cable H07RNF with free terminals (SCHUKO-plug for single phase versions)

Rotation: clockwise seen from above

P1 = maximum power consumption

P2 = maximum power at the motor shaft

MOTOR SHAFT and BEARINGS

The wet end's side of motor shafts is made out of stainless steel type AISI 420.

Motor shafts are supported by two high quality lifetime lubricated bearings (SKF or equivalent).

MECHANICAL SEALS

Shaft sealing by two mechanical shaft seals (BURGMANN or equivalent) in tandem arrangement, independent to direction of rotation, with sliding surfaces in sil./sil. in oil chamber. In case of failure of the first mechanical seal the second guarantee the safe working of the electropump :

- Seal types applied to the motor side :

COMPATTA, AM 32 and AM 40 series: high quality radial lip seals

on motor types 125/152/173 : high quality Carbon - Ceramic

on motor types 200/240/340: wear resistant Silicon -



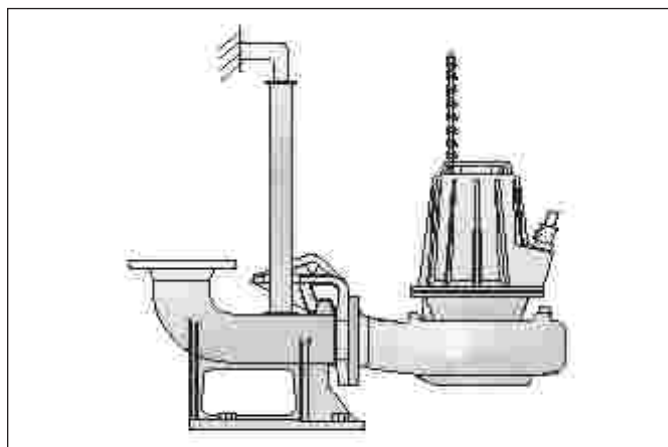

Carbide+Viton

- Seal types applied to the wet end side :

are for all pump versions: wear resistant Silicon -Carbide+Viton

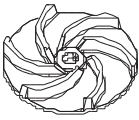
**INSTALLAZIONE FISSA
INSTALLATION FIXE**

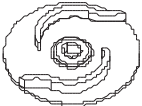
**SELEZIONE DI GIRANTE PER APPLICAZIONI PIU' COMUNI
IMPELLER SELECTION FOR APPLIANCES MORE COMMON**

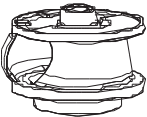
| GIRANTE TIPO IMPELLER TYPE DISEGNI DELLE GIRANTI | POMPA TIPO PUMP TYPE | TIPO DI ACQUE DA POMPARE TYPE OF WATER TO PUMP | | | | |
|---|---------------------------|---|---------------------------|---|--|--|
| | | CHIARE CLEAR | FOGNATURA SEWERAGE | CONTENENTE CORPI SOLIDI CONTAINING SOLIS BODIES! | CONTENENTE CORPI FILAMENTOSI CONTAINING FILAMENTOUS BODIES! | LIQUIDI ABBRASIVI ABRASIVE LIQUIDIS |
|  VORTEX | COMPATTA VM-VT | ● | ● | ● | ● | ● |
|  TRITURATORE GRINDER | GM-GT | | ● | | ● | |
|  BICANALE APERTA TWIN OPEN | AM-AT | ● | | | | |
|  MONOCANALE APERTO SINGLE CHANNEL OPEN | AM-AT | ● | ● | ● | ● | |
|  MONOCANALE CHIUSO SINGLE CHANNEL CLOSED | AM-AT | ● | ● | ● | | ● |

FUNZIONAMENTO 50 Hz - WORKING 50Hz

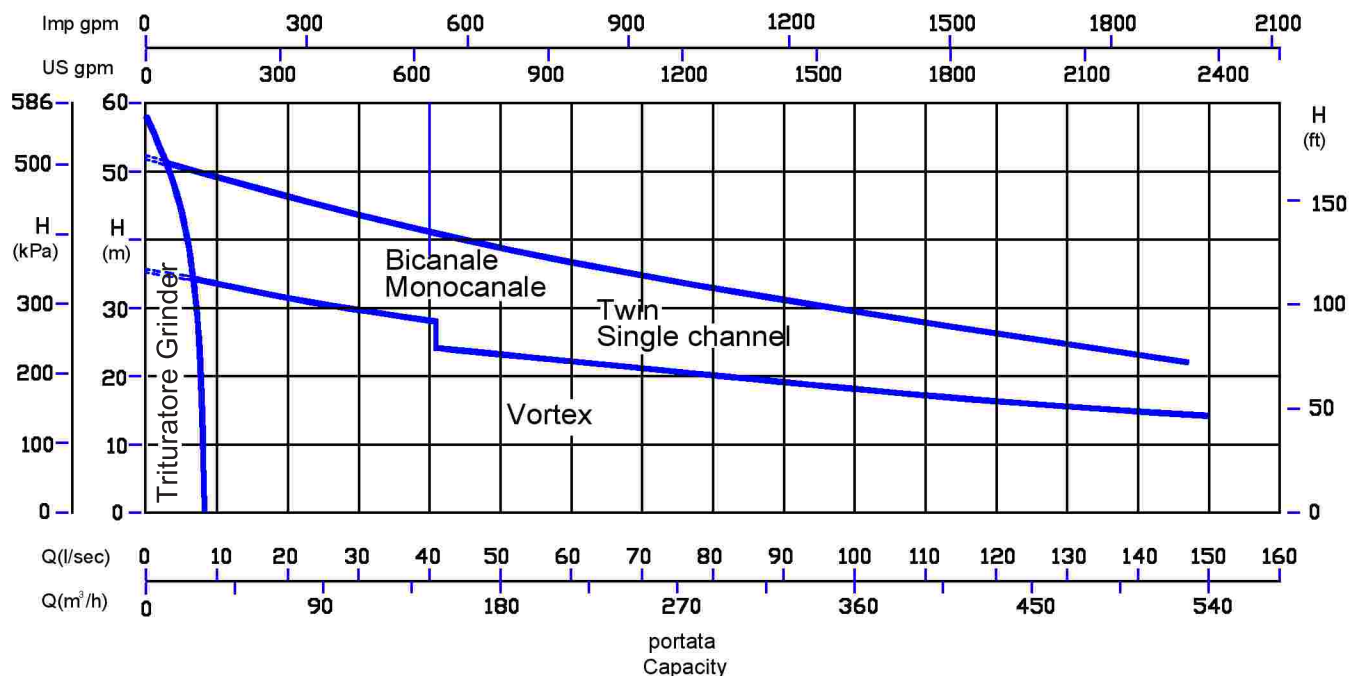

TIPO DI APPLICAZIONI IN FUNZIONE DELLE GIRANTI - APPLIANCES TYPE FOR THE IMPELLERS

| APPLICAZIONI APPLIANCES | COMPATTA VM-VT VORTEX | AM -AT BICANALE TWIN | AM - AT MONOCANALE SINGLE CHANNEL | GM -GT TRITURATORE GRINDER |
|--|--------------------------|----------------------------|---|----------------------------------|
| Scarichi fognari –impianti condominiali Impianti delle comunità <i>Sewer dumpings- condominial plants Community plants</i> | ● | | ● | ● |
| Scarichi Industria Impianti di depurazione <i>Industrial dumpings purification plants</i> | ● | ● | ● | |
| Scarichi fanghi <i>Muds dumpings</i> | | ● | ● | |
| Scarichi Allevamenti <i>Farms dumpings</i> | ● | | ● | |
| Allevamenti con percentuale di paglia <i>Farms with proportional of straw</i> | | | | ● |
| Agricoltura <i>Agriculture</i> | ● | ● | ● | |
| Cantieristica edile <i>Building industry</i> | | ● | ● | |

COMPATTA 2-3

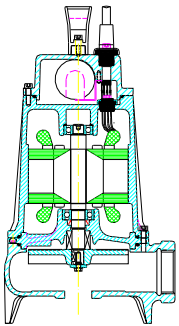

GIRANTE VORTEX
VORTEX IMPELLER



| | |
|------------------|------|
| PASSAGGIO LIBERO | 40mm |
| FREE PASSAGE | 40mm |

| | |
|---------------|----------|
| ALBERO MOTORE | AISI 420 |
| MOTOR SHAFT | AISI 420 |

Curve secondo ISO 9906. Livello 2

Curves as per ISO 9906. Grade 2

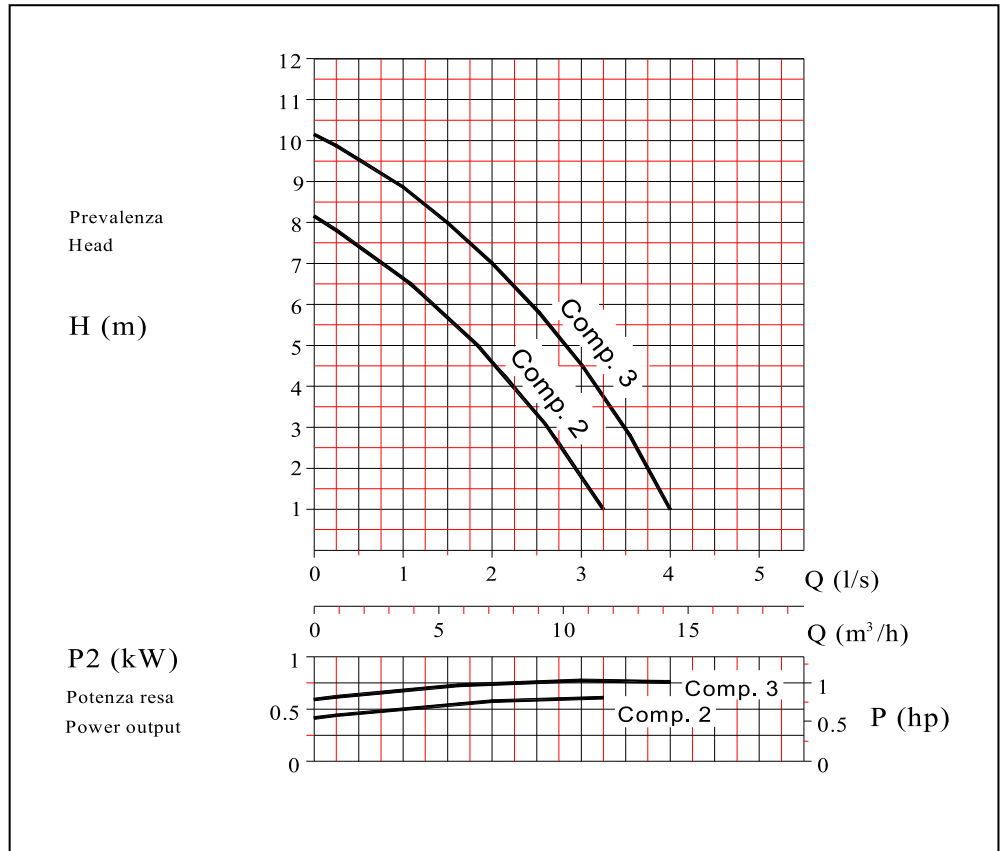

| Elettropompa Tipo Electric pump Type | Prevalenza - Head | | | | | | | | | | | | | | | | | | | | | |
|---|-------------------|------|-----|------|------|------|------|------|-----|------|-----|--------------------|--|--|--|--|--|--|--|--|--|--|
| | Hm bar | | | | | | | | | | | | | | | | | | | | | |
| | 1 | 2 | 3 | 4 | 5 | 6 | 7 | 8 | 9 | 10 | 11 | | | | | | | | | | | |
| | 0,1 | 0,2 | 0,3 | 0,4 | 0,5 | 0,6 | 0,7 | 0,8 | 0,9 | 1 | 1,1 | Portata - Capacity | | | | | | | | | | |
| | Q (l/s) | | | | | | | | | | | | | | | | | | | | | |
| COMPATTA 2 M/T | 3,25 | 2,9 | 2,6 | 2,25 | 1,75 | 1,25 | 0,75 | 0,15 | | | | | | | | | | | | | | |
| COMPATTA 3 M/T | 4 | 3,75 | 3,5 | 3,25 | 2,75 | 2,5 | 2 | 1,5 | 0,9 | 0,15 | | | | | | | | | | | | |

Dati tecnici / Specifications

| | Mandata Delivery | kW | | r.p.m | Poles | Hz | Ampere | | |
|----------------|---------------------|------|------|-------|-------|----|--------|----|----------|
| | | P1 | P2 | 1/min | | | 1~ | | 400 V 3~ |
| | | | | | | | 230 V | uf | |
| COMPATTA 2 M/T | G 1 1/2" | 0,73 | 0,59 | 2850 | 2 | 50 | 4,3 | 16 | 1,5 |
| COMPATTA 3 M/T | | 0,93 | 0,75 | 2850 | 2 | 50 | 5,1 | 20 | 1,9 |

M = 1~ 230 VOLT - 50 Hz T = 3~ 400 VOLT - 50 Hz

Dimensioni di ingombro dell'imballo
Overall dimensions of packing

| TIPO-TYPE | X | Y | Z | Kg |
|----------------|-----|-----|-----|------|
| COMPATTA 2 M/T | 250 | 440 | 210 | 14,5 |
| COMPATTA 3 M/T | 250 | 440 | 210 | 15,5 |

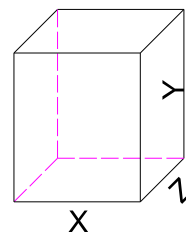

Specifiche costruttive disegni e fotografie sono Modificabili senza alcun preavviso
Constructive specifications designs and photos are modifiable without any notice

Dimensioni - Dimensions

Compatta 2-3



INSTALLAZIONE FISSA
STATIONARY INSTALLATION

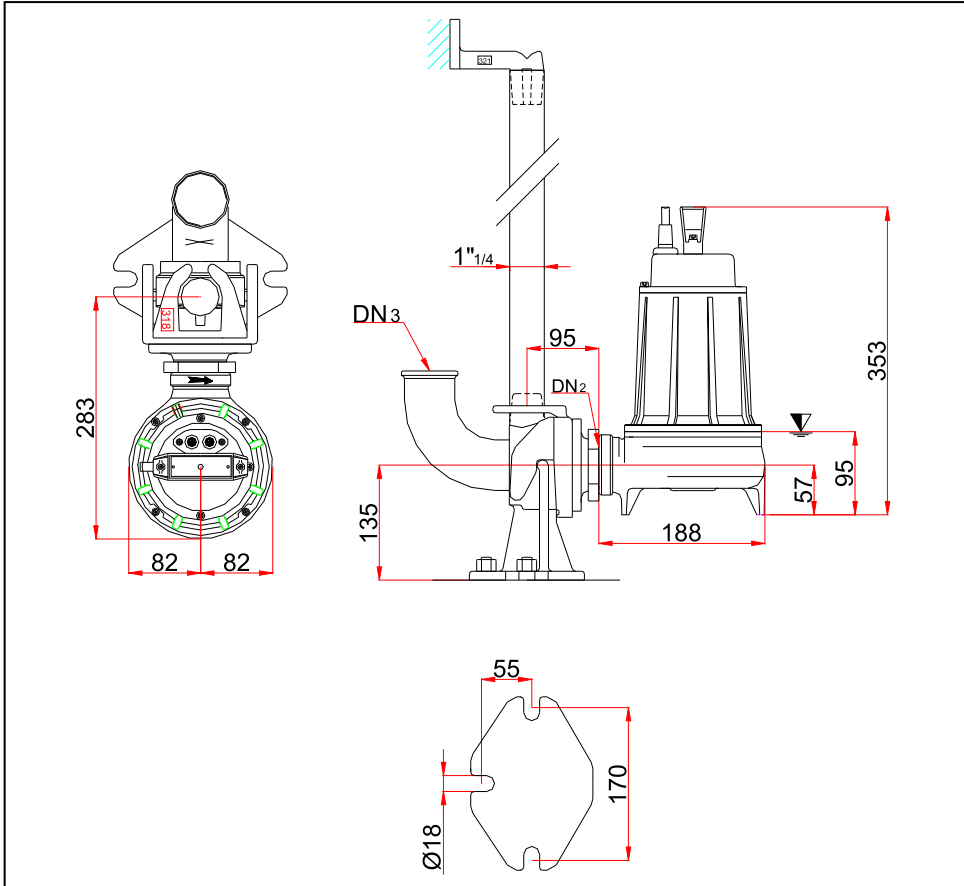

Punto inferiore d'arresto nel caso di funzionamento automatico
Lowest shut-off point for automatic operation

CARATTERISTICHE TECNICHE - TECHNICAL FEATURES

| TIPO - TYPE | DN2 Mandata filettata | DN3 | CAVO - CABLE H07 - RNF | MT | | | | | OPTIONAL |
|------------------------------|--------------------------|-----------|--|-----------|---------------------------|---------------------------|---------------------------|---------------------------|---------------------|
| | | | | | | | | | |
| Compatta 2 M Compatta 3 M | G 1 1/2 " | 2" | (1) 3x1 φ 9 Schuko-plug | 10 | Superiore <i>Upper</i> | Inferiore <i>Lower</i> | Superiore <i>Upper</i> | Inferiore <i>Lower</i> | TIPO: B2 |
| Compatta 2 T Compatta 3 T | | | (1) 4x1 φ 10 con terminali liberi <i>with free cable terminals</i> | | SC 15-24-5 | MG1S2/14/G1 | 6201 2Z | 6202 2Z | |

COMPATTA 4-5

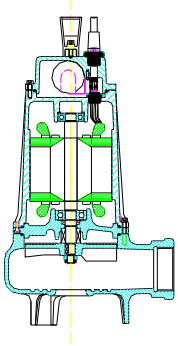

GIRANTE VORTEX
VORTEX IMPELLER



| | |
|------------------|------|
| PASSAGGIO LIBERO | 50mm |
| FREE PASSAGE | 50mm |

| | |
|---------------|----------|
| ALBERO MOTORE | AISI 420 |
| MOTOR SHAFT | Ø 420 |

Curve secondo ISO 9906 Livello 2
Curves as per ISO 9906. Grade 2

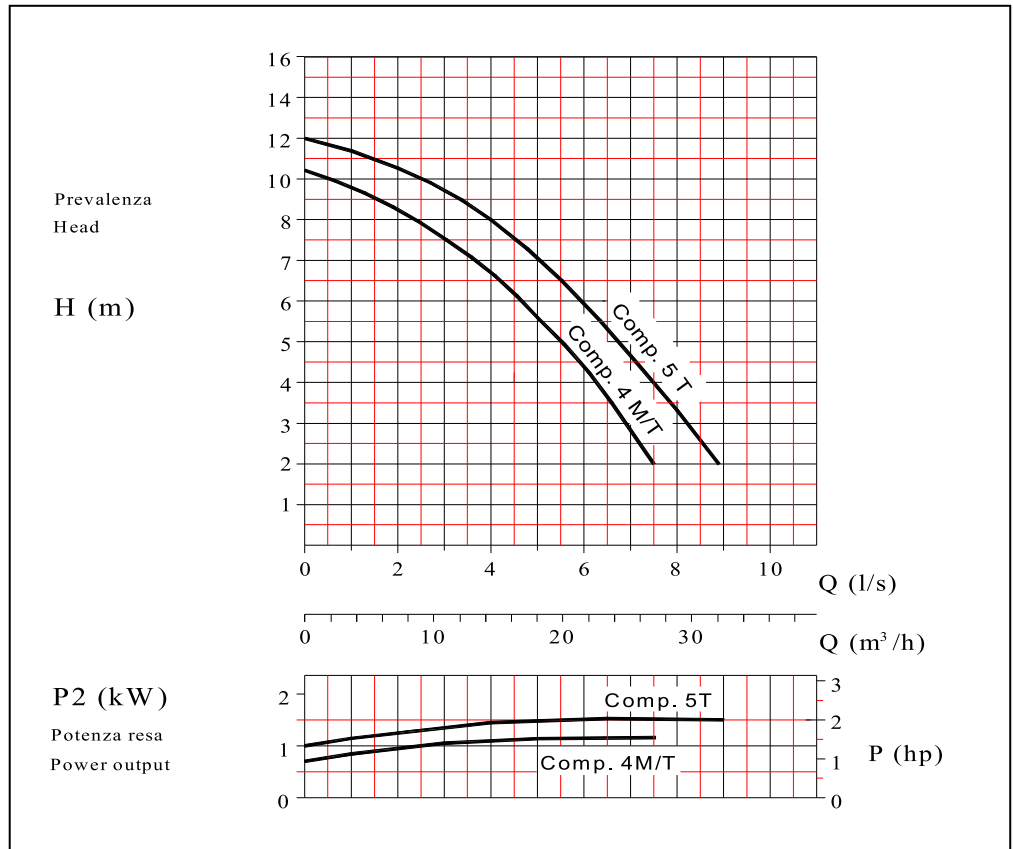

| Elettropompa Tipo Electric pump Type | Prevalenza - Head | | | | | | | | | | |
|---|--------------------|-----|------|------|------|-----|-----|-----|-----|-----|-----|
| | Hm bar | | | | | | | | | | |
| | 1 | 2 | 3 | 4 | 5 | 6 | 7 | 8 | 9 | 10 | 12 |
| | 0,1 | 0,2 | 0,3 | 0,4 | 0,5 | 0,6 | 0,7 | 0,8 | 0,9 | 1 | 1,2 |
| | Portata - Capacity | | | | | | | | | | |
| | Q (l/s) | | | | | | | | | | |
| COMPATTA 4 T/M | | 7,5 | 6,8 | 6,25 | 5,5 | 4,5 | 3,5 | 2,5 | 1,5 | 0,5 | |
| COMPATTA 5 T | | 9 | 8,25 | 7,5 | 6,75 | 6 | 5 | 4 | 3,5 | 2,5 | |

Dati tecnici / Specifications

| | Mandata Delivery | kW | | r.p.m | Poles | Hz | Ampere | | |
|----------------|---------------------|-----|-----|-------|-------|----|--------|----------|-----|
| | | P1 | P2 | 1/min | | | 230 V | 400 V 3~ | |
| | | | | | | | | 1~ | uf |
| COMPATTA 4 T/M | G 2" | 1,4 | 1,1 | 2850 | 2 | 50 | 8,3 | 30 | 2,8 |
| COMPATTA 5 T | | 1,9 | 1,5 | 2850 | 2 | 50 | | | 3,6 |

M = 1~ 230 VOLT - 50 Hz T = 3~ 400 VOLT - 50 Hz

Dimensioni di ingombro dell'imballo
Overall dimensions of packing

| TIPO-TYPE | X | Y | Z | Kg |
|----------------|-----|-----|-----|----|
| COMPATTA 4 T/M | 250 | 440 | 210 | 20 |
| COMPATTA 5 T | 250 | 440 | 210 | 21 |

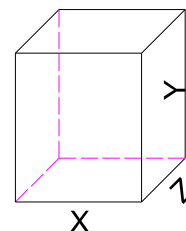



Dimensioni - Dimensions

Compatta 4-5



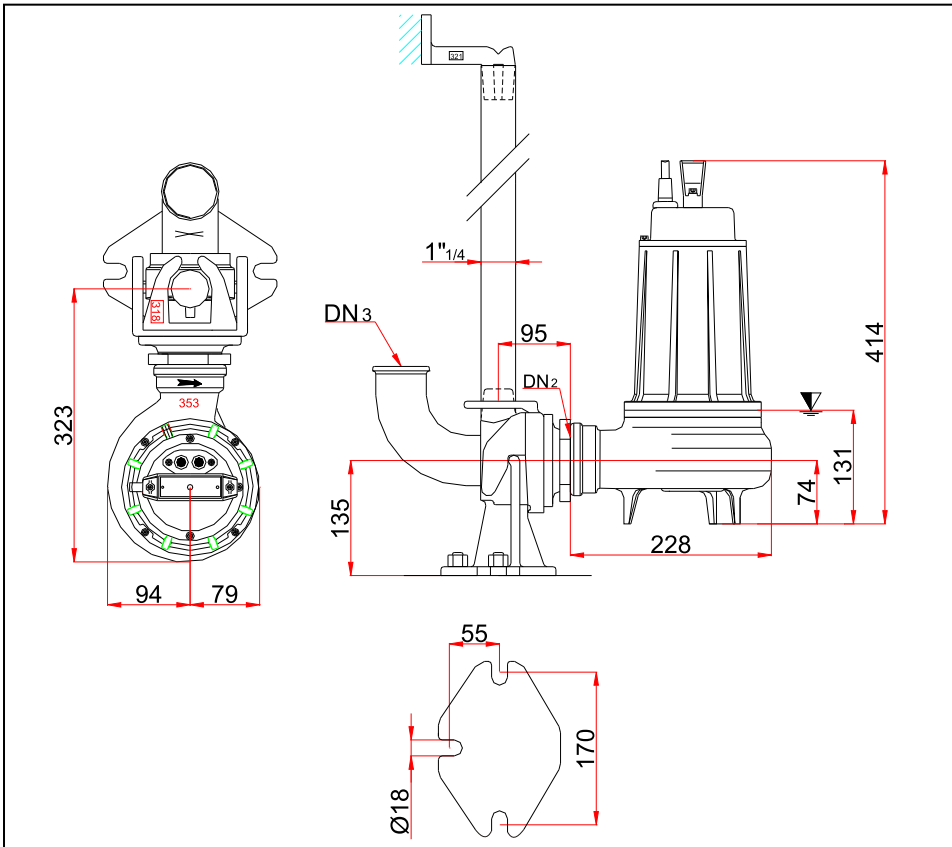

INSTALLAZIONE FISSA
STATIONARY INSTALLATION



 Punto inferiore d'arresto nel caso di funzionamento automatico
Lowest shut-off point for automatic operation

CARATTERISTICHE TECNICHE - TECHNICAL FEATURES

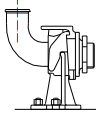
| TIPO - TYPE | DN2 Mandata filettata | DN3 | CAVO - CABLE H07 - RNF | MT | | | | | OPTIONAL |
|------------------------------|--------------------------|-----------|--|-----------|---|---|---|--------------------|---|
| | | | | |  |  |  | |  |
| Compatta 4 M | G 2" | 2" | (1) 3x1φ 9 Schuko-plug | 10 | Superiore Upper | Inferiore Lower | Superiore Upper | Inferiore Lower | |
| Compatta 4 T Compatta 5 T | | | (1) 4x1φ 10 con terminali liberi with free cable terminals | | SC15-24-5 | MG1S2/14/G1 | 6202 2Z | 6302 2Z | TIPO: B3 |

COMPATTA 5-6

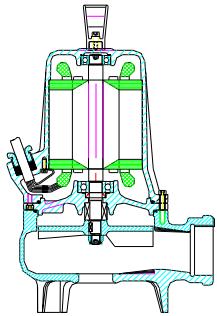

GIRANTE VORTEX
VORTEX IMPELLER

| | |
|------------------|------|
| PASSAGGIO LIBERO | 50mm |
| FREE PASSAGE | 50mm |
| PASSAGE | |

| | |
|---------------|----------|
| ALBERO MOTORE | AISI 420 |
| MOTOR SHAFT | AISI 420 |

Curve secondo ISO 9906. Livello 2

Curves as per ISO 9906. Grade 2

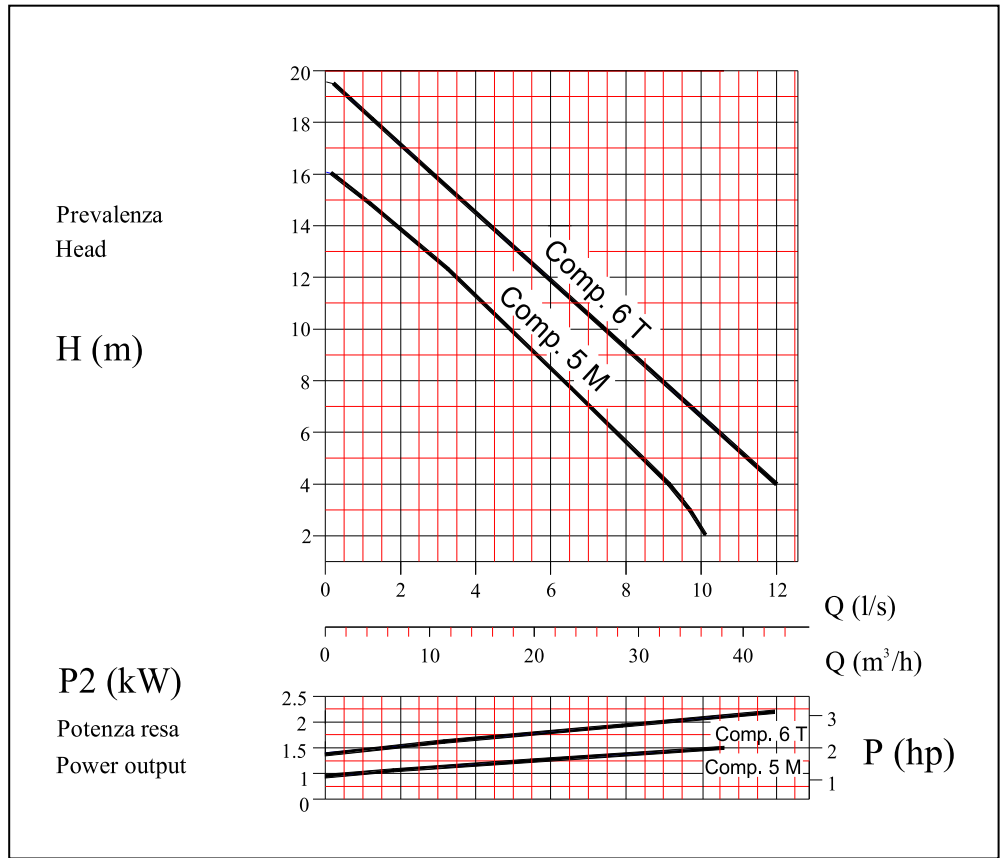

| Elettropompa Tipo Electric pump Type | Prevalenza - Head | | | | | | | | | | |
|---|--------------------|-----|-----|------|-----|-----|-----|-----|------|-----|----|
| | Hm bar | | | | | | | | | | |
| | 1 | 2 | 4 | 6 | 8 | 10 | 12 | 14 | 16 | 18 | 20 |
| | Portata - Capacity | | | | | | | | | | |
| | Q (l/s) | | | | | | | | | | |
| | 0,1 | 0,2 | 0,4 | 0,6 | 0,8 | 1 | 1,2 | 1,4 | 1,6 | 1,8 | 2 |
| COMPATTA 5 M | | 10 | 9 | 7,7 | 6,3 | 4,9 | 3,5 | 1,8 | | | |
| COMPATTA 6 T | | | 12 | 10,5 | 9 | 7,5 | 5,9 | 4,4 | 2,75 | 1,3 | |

Dati tecnici / Specifications

| | Mandata Delivery | kW | | r.p.m | Poles | Hz | Ampere | | |
|--------------|------------------|----|-----|-------|-------|----|--------|----|----------|
| | | P1 | P2 | 1/min | | | 1~ | | 400 V 3~ |
| | | | | | | | 230 V | uf | |
| COMPATTA 5 M | G 2" | 2 | 1,5 | 2850 | 2 | 50 | 9,2 | 40 | |
| COMPATTA 6 T | | 3 | 2,2 | 2850 | 2 | 50 | | | 5,2 |

M = 1~ 230 VOLT - 50 Hz T = 3~ 400 VOLT - 50 Hz

Dimensioni di ingombro
Overall dimensions of packing

| TIPO-TYPE | X | Y | Z | Kg |
|--------------|-----|-----|-----|------|
| COMPATTA 5 M | 250 | 440 | 210 | 20,5 |
| COMPATTA 6 T | 250 | 440 | 210 | 21 |

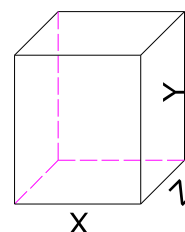



Dimensioni - Dimensions

Compatta 5-6

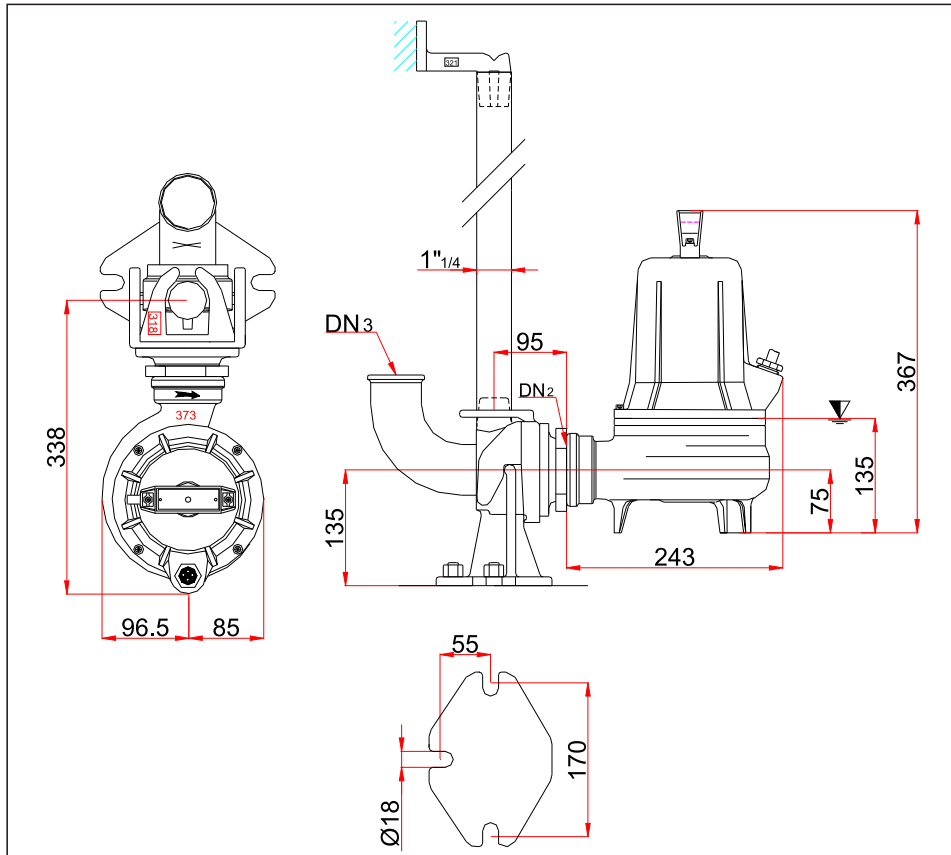

INSTALLAZIONE FISSA
STATIONARY INSTALLATION



 Punto inferiore d'arresto nel caso di funzionamento automatico
Lowest shut-off point for automatic operation

CARATTERISTICHE TECNICHE - TECHNICAL FEATURES

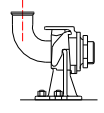
| TIPO - TYPE | DN2 Mandata filettata | DN3 | CAVO - CABLE H07 - RNF (1) 4x1,5 φ11,5 Pannello di controllo Control panel | MT |  | | | | OPTIONAL |
|--------------|--------------------------|-----|--|----|--|--------------------|--------------------|--------------------|---|
| | | | | | Superiore Upper | Inferiore Lower | Superiore Upper | Inferiore Lower |  |
| Compatta 5 M | G 2" | 2" | (1) 4x1,5 φ 11,5 con terminali liberi with free cable terminals | 10 | SC 15/24/5 | MG1S2/14/G1 | 6202 2Z | 6302 2Z | TIPO: B3 |
| Compatta 6 T | | | | | | | | | |

VT 65/2/152 C. 346-347

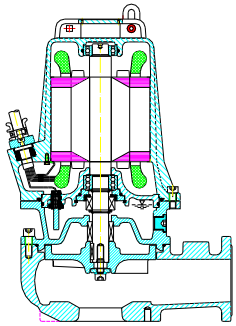

GIRANTE VORTEX
IMPELLER VORTEX



| | |
|------------------|------|
| PASSAGGIO LIBERO | 60mm |
| FREE PASSAGE | 60mm |

| | |
|---------------|----------|
| ALBERO MOTORE | AISI 420 |
| MOTOR SHAFT | AISI 420 |

Curve secondo ISO 9906. Livello 2
Curves as per ISO 9906. Grade 2

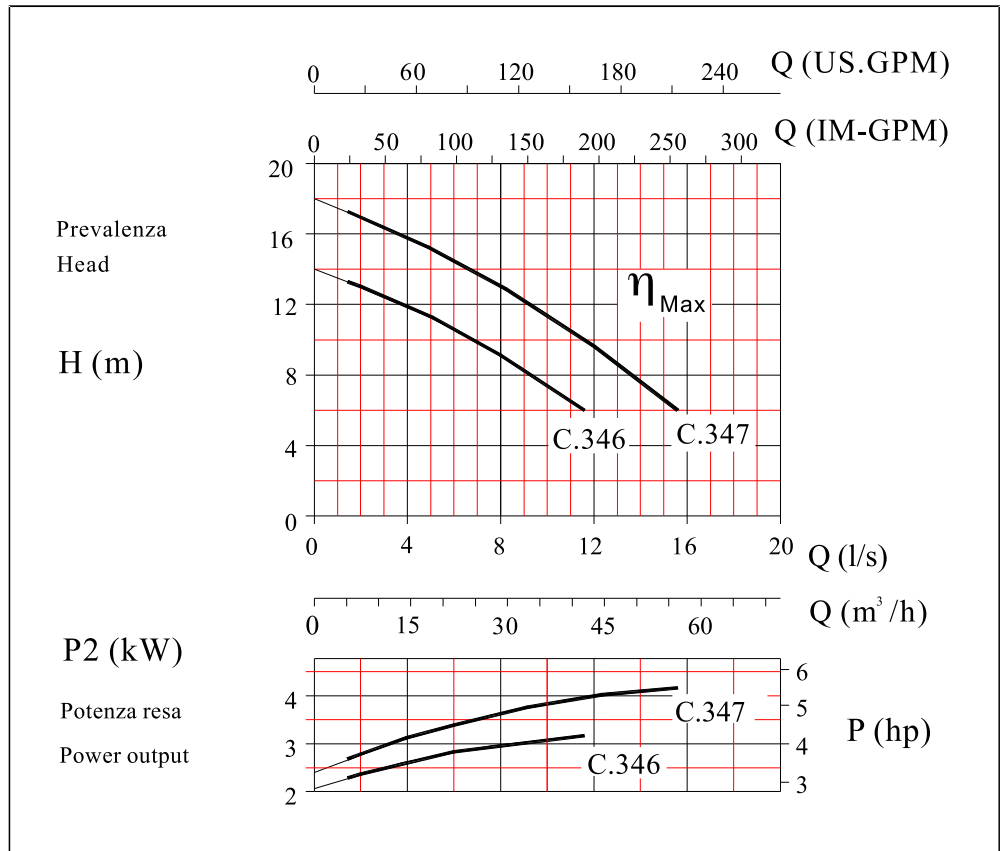

| Elettropompa Tipo Electric pump Type | Prevalenza - Head | | | | | | | | | | |
|---|-------------------|-----|-----|-----|-----|----|-----|-----|-----|-----|----|
| | Hm bar | | | | | | | | | | |
| | 1 | 2 | 4 | 6 | 8 | 10 | 12 | 14 | 16 | 18 | 20 |
| | 0,1 | 0,2 | 0,4 | 0,6 | 0,8 | 1 | 1,2 | 1,4 | 1,6 | 1,8 | 2 |
| Portata - Capacity | | | | | | | | | | | |
| Q (l/s) | | | | | | | | | | | |
| VT 65/2/152 C.346 | | | | 12 | 9 | 7 | 4 | | | | |
| VT 65/2/152 C.347 | | | | 16 | 14 | 12 | 9 | 7 | 4 | | |

Dati tecnici / Specifications

| | Mandata Delivery | kW | | r.p.m | Poles | Ampere Trifase 3~ 400V | Hz | Cos j |
|-------------------|---------------------|-----|-----|-------|-------|------------------------------|----|-------|
| | | P1 | P2 | 1/min | | | | |
| VT 65/2/152 C.346 | DN2 65 | 4,3 | 3,2 | 2850 | 2 | 7,1 | 50 | 0,89 |
| VT 65/2/152 C.347 | | 5,7 | 4,2 | 2850 | 2 | 9,0 | 50 | 0,9 |

Dimensioni di ingombro dell'imballo
Overall dimensions of packing

| TIPO-TYPE | X | Y | Z | Kg |
|--------------------|-----|-----|-----|----|
| VT 65/2/152 C. 346 | 340 | 550 | 420 | 58 |
| VT 65/2/152 C. 347 | 340 | 550 | 420 | 59 |

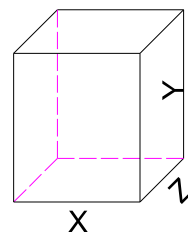

Dimensioni - Dimensions

VT 65/2/152 C.346-347



INSTALLAZIONE FISSA
STATIONARY INSTALLATION

INSTALLAZIONE MOBILE
MOBILE INSTALLATION

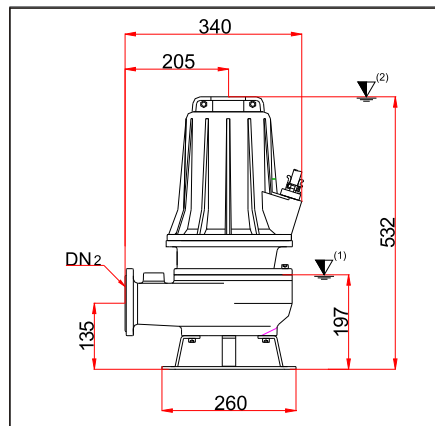
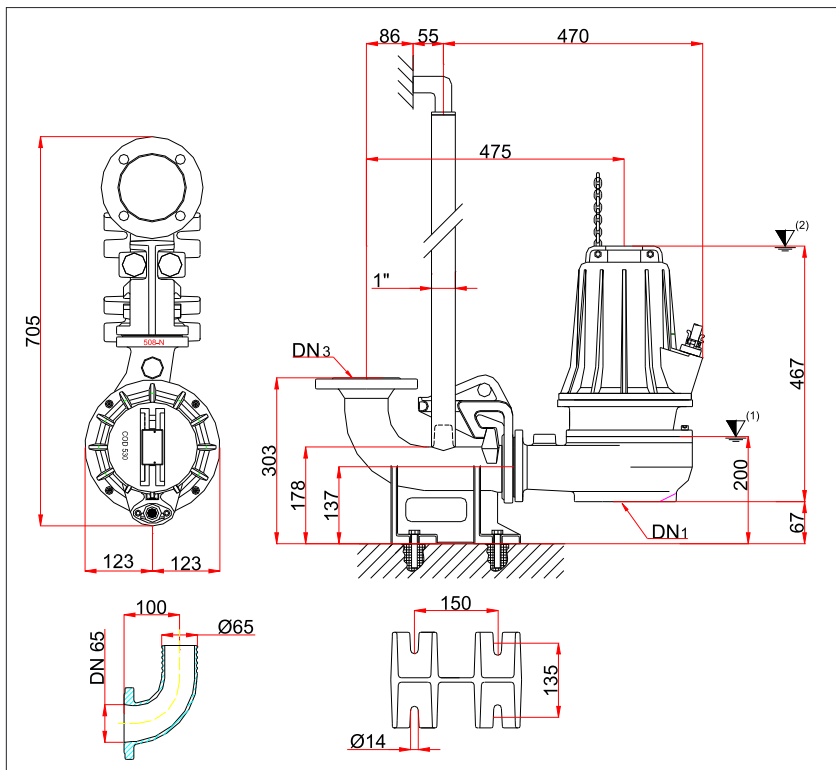

Dimensioni flange UNI
UNI flange dimensions

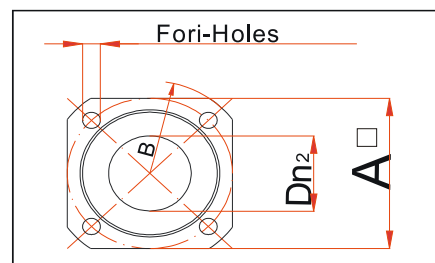

DIMENSIONI FLANGE UNI - UNI FLANGE DIMENSIONS

| TIPO - TYPE | DN 1 | DN 2/3 | A | B | Fori - Holes - Trous | | OPTIONAL | | | |
|--|------|--------|-----|-----|----------------------|------|----------|----------|-------|--|
| | | | | | n° | φ mm | | | | |
| VT 65/2/152 C.346 VT 65/2/125 C.337 | 65 | 65 | 130 | 160 | 4 | 14 | P4-DN 65 | B4-DN 65 | DN 65 | |

CARATTERISTICHE TECNICHE - TECHNICAL FEATURES

| TIPO - TYPE | CAVO - CABLE H07 - RNF | MT | Sonde termiche | si | | | | |
|--|--------------------------------|----|-----------------------|-----|--------------------|--------------------|--------------------|--------------------|
| | | | Thermal probes | yes | Superiore Upper | Inferiore Lower | Superiore Upper | Inferiore Lower |
| VT 65/2/152 C.346 VT 65/2/152 C.347 | (1) 7x1,5 φ 15 AVV. DIRETTO | 10 | Sonda di conduttività | si | AR 25 | MG1/25 - G6 | 6205 2Z | 3205 2Z |
| | | | Conductivity probe | yes | | | | |

NOTE - NOTES :



Punto inferiore d'arresto nel caso di funzionamento automatico
Lowest shut-off point for automatic operation



Sommergenza minima nel caso di funzionamento continuo
Minimum covering for continuous operation

VT 80/2/173 C. 354-357

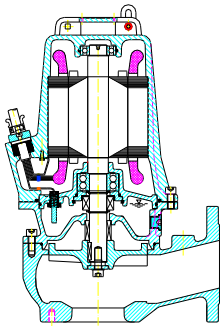

GIRANTE VORTEX
IMPELLER VORTEX



| | |
|------------------|------|
| PASSAGGIO LIBERO | 70mm |
| FREE PASSAGE | 70mm |
| PASSAGE | |

| | |
|---------------|----------|
| ALBERO MOTORE | AISI 420 |
| MOTOR SHAFT | AISI 420 |

Curve secondo ISO 9906. Livello 2
Curves as per ISO 9906. Grade 2

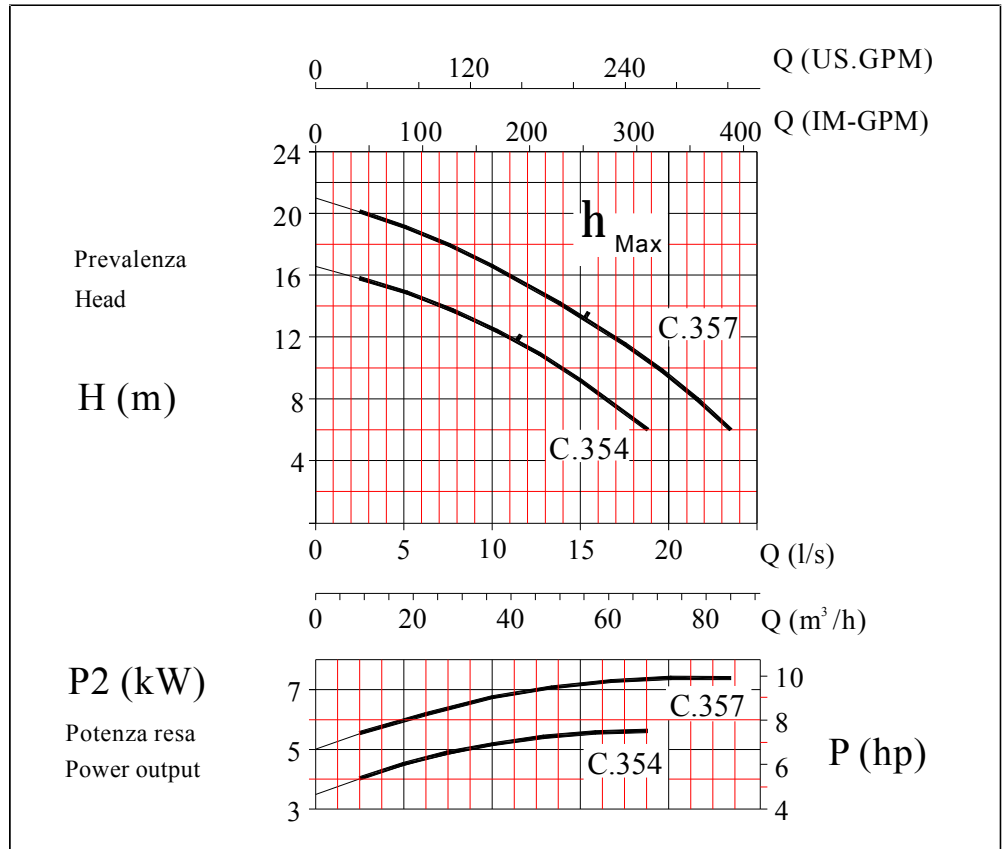

| Elettropompa Tipo Electric pump Type | Prevalenza - Head | | | | | | | | | | |
|---|--------------------|-----|-----|----|-----|-----|-----|-----|-----|-----|-----|
| | Hm bar | | | | | | | | | | |
| | 4 | 6 | 8 | 10 | 12 | 14 | 16 | 18 | 20 | 21 | 22 |
| | 0,4 | 0,6 | 0,8 | 1 | 1,2 | 1,4 | 1,6 | 1,8 | 2 | 2,1 | 2,2 |
| | Portata - Capacity | | | | | | | | | | |
| | Q (l/s) | | | | | | | | | | |
| VT 80/2/173 C.354 | | 19 | 16 | 14 | 11 | 7 | 2,5 | | | | |
| VT 80/2/173 C.357 | | 23 | 21 | 19 | 17 | 14 | 11 | 7 | 2,5 | | |

Dati tecnici / Specifications

| | Mandata Delivery | kW | | r.p.m | Poles | Ampere | Hz | Cos j |
|-------------------|---------------------|-----|-----|-------|-------|------------|----|-------|
| | | P1 | P2 | 1/min | | Trifase 3~ | | |
| | | | | | | 400V | | |
| VT 80/2/173 C.354 | DN2 80 | 7,5 | 5,5 | 2850 | 2 | 12,5 | 50 | 0,88 |
| VT 80/2/173 C.357 | DN2 80 | 9,9 | 7,2 | 2850 | 2 | 15,7 | 50 | 0,90 |

Dimensioni di ingombro dell'imballo
Overall dimensions of packing

| TIPO-TYPE | X | Y | Z | Kg |
|-------------------|-----|-----|-----|----|
| VT 80/2/173 C.354 | 340 | 550 | 420 | 86 |
| VT 80/2/173 C.357 | 340 | 550 | 420 | 87 |

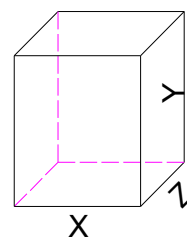

Dimensioni - Dimensions

VT 80/2/173 C.354-357



INSTALLAZIONE FISSA
STATIONARY INSTALLATION

INSTALLAZIONE MOBILE
MOBILE INSTALLATION

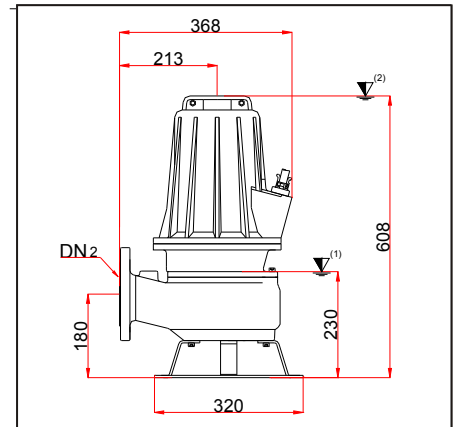
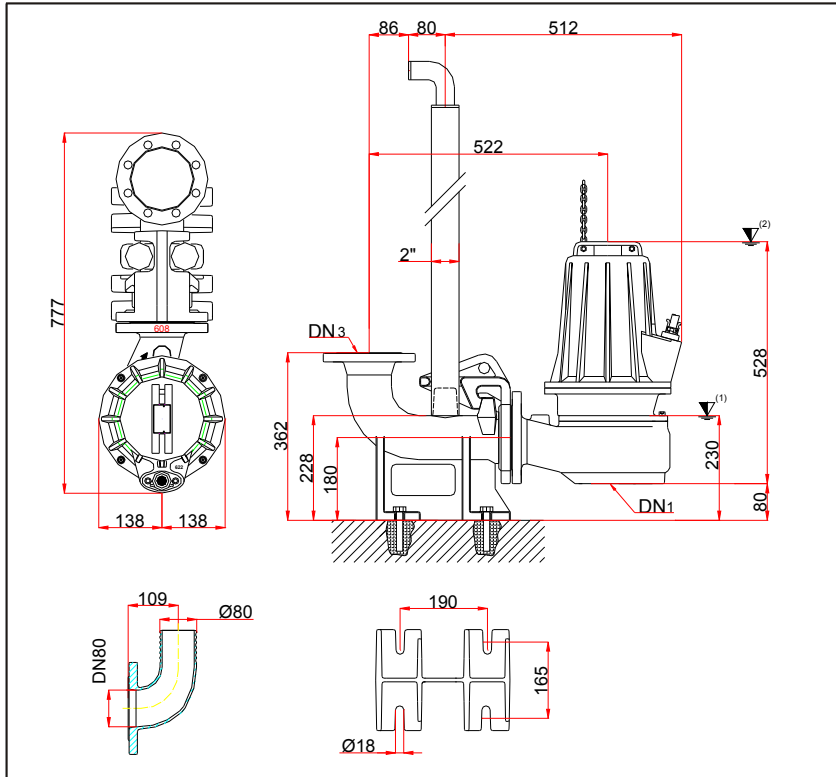

Dimensioni flange UNI
UNI flange dimensions

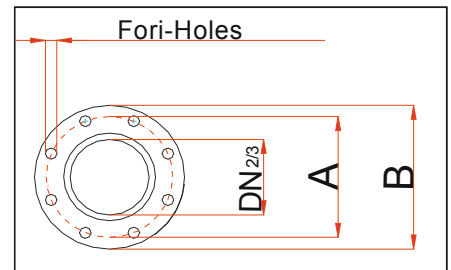

DIMENSIONI FLANGE UNI - UNI FLANGE DIMENSIONS

| TIPO - TYPE | DN 1 | DN 2/3 | A | B | Fori - Holes - Trous | | OPTIONAL | | | |
|--|------|--------|-----|-----|----------------------|------|----------|----------|---------------|--|
| | | | | | n° | φ mm | | | | |
| VT 80/2/173 C.354 VT 80/2/173 C.357 | 80 | 80 | 160 | 200 | 8 | 18 | P5-DN 80 | B5-DN 80 | DN 80 - PN 16 | |

CARATTERISTICHE TECNICHE - TECHNICAL FEATURES

| TIPO - TYPE | CAVO - CABLE H07 - RNF | MT | Sonde termiche | si | | | | |
|--|---------------------------|----|-----------------------|-----|-----------|-----------|-----------|-----------|
| | | | Thermal probes | yes | | | | |
| VT 80/2/173 C.354 VT 80/2/173 C.357 | (1) 10x1,5 φ 20 Y-Δ | 10 | Sonda di conduttività | si | Superiore | Inferiore | Superiore | Inferiore |
| | | | Conductivity probe | yes | AR 30 | MG1/30/G6 | 6206 2Z | 3306 2Z |

NOTE - NOTES - NOTES :



Punto inferiore d'arresto nel caso di funzionamento automatico
Lowest shut-off point for automatic operation



Sommergenza minima nel caso di funzionamento continuo
Minimum covering for continuous operation

VT 80/2/200 C. 367- 368

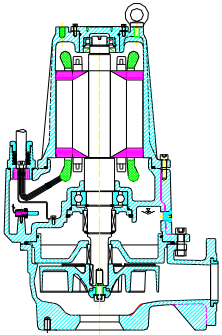

GIRANTE VORTEX
IMPELLER VORTEX



| | |
|------------------|------|
| PASSAGGIO LIBERO | 70mm |
| FREE PASSAGE | 70mm |

| | |
|---------------|----------|
| ALBERO MOTORE | AISI 420 |
| MOTOR SHAFT | AISI 420 |

Curve secondo ISO 9906. Livello 2
Curves as per ISO 9906. Grade 2

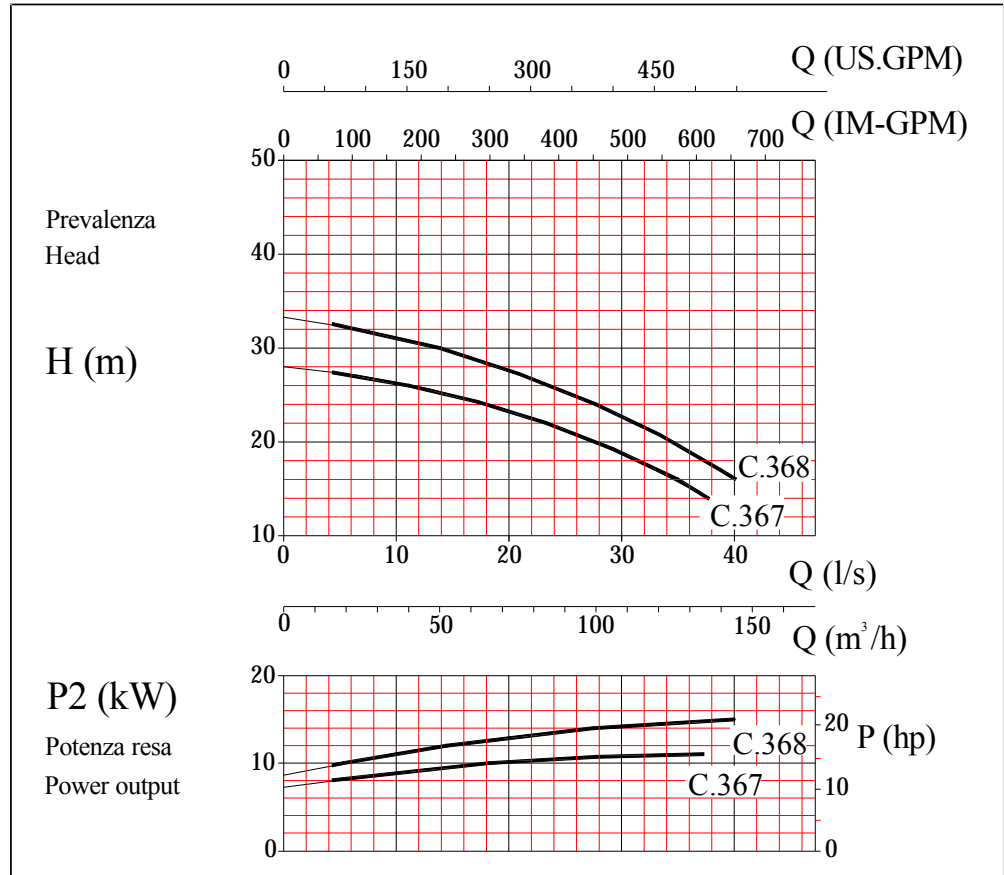

| Elettropompa Tipo Electric pump Type | Prevalenza - Head | | | | | | | | | | |
|---|--------------------|-----|-----|-----|----|-----|-----|-----|-----|----|-----|
| | Hm bar | | | | | | | | | | |
| | 12 | 14 | 16 | 18 | 20 | 22 | 24 | 26 | 28 | 30 | 32 |
| | 1,2 | 1,4 | 1,6 | 1,8 | 2 | 2,2 | 2,4 | 2,6 | 2,8 | 3 | 3,2 |
| | Portata - Capacity | | | | | | | | | | |
| | Q (l/s) | | | | | | | | | | |
| VT 80/2/200 C.367 | | 38 | 34 | 32 | 28 | 22 | 18 | 10 | | | |
| VT 80/2/200 C.368 | | | 40 | 38 | 34 | 31 | 28 | 24 | 20 | 14 | 6 |

Dati tecnici / Specifications

| | Mandata Delivery | kW | | r.p.m | Poles | Ampere | Hz | Cos j |
|-------------------|---------------------|------|------|-------|-------|------------|----|-------|
| | | P1 | P2 | 1/min | | Trifase 3~ | | |
| | | | | | | 400V | | |
| VT 80/2/200 C.367 | DN2 80 | 14,8 | 11 | 2850 | 2 | 21 | 50 | 0,81 |
| VT 80/2/200 C.368 | | 19,8 | 14,7 | 2850 | 2 | 30 | 50 | 0,81 |
| | | | | | | | | |

Dimensioni di ingombro dell'imballo
Overall dimensions of packing

| TIPO-TYPE | X | Y | Z | Kg |
|-------------------|-----|-----|-----|-----|
| VT 80/2/200 C.367 | 550 | 860 | 645 | 185 |
| VT 80/2/200 C.368 | 550 | 860 | 645 | 195 |

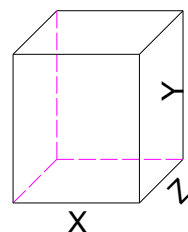

Dimensioni - Dimensions

VT 80/2/200 C.367-368



INSTALLAZIONE FISSA
STATIONARY INSTALLATION

INSTALLAZIONE MOBILE
MOBILE INSTALLATION

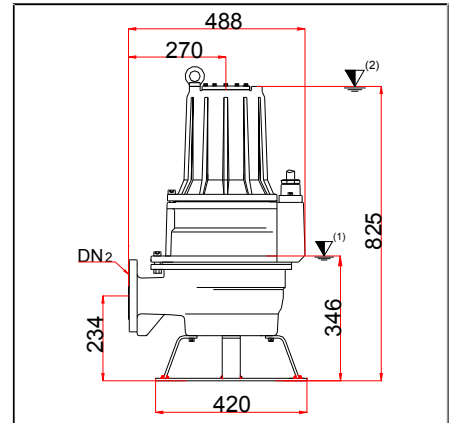
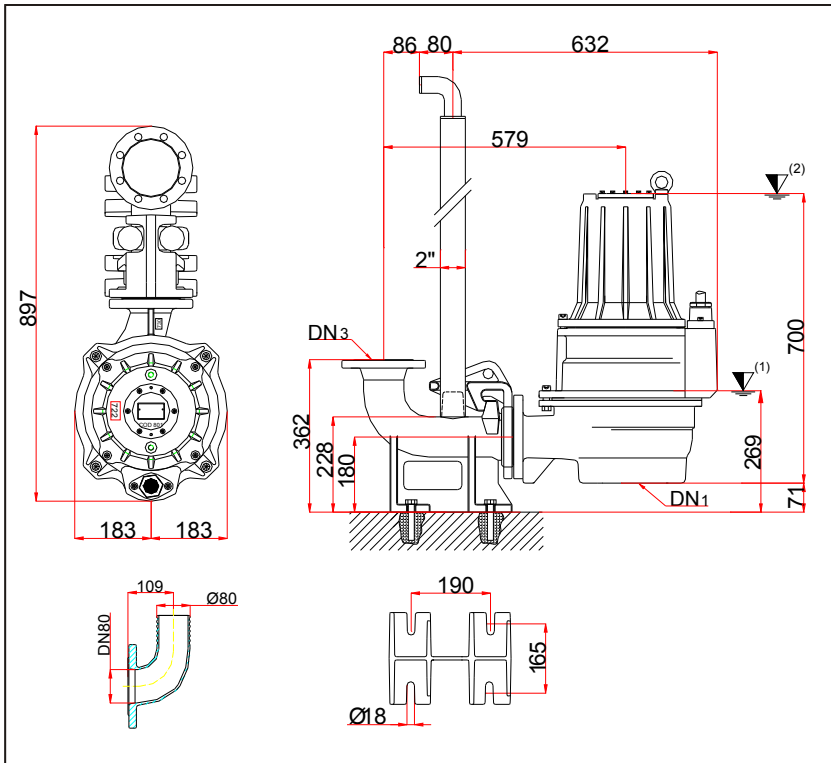

Dimensioni flange UNI
UNI flange dimensions

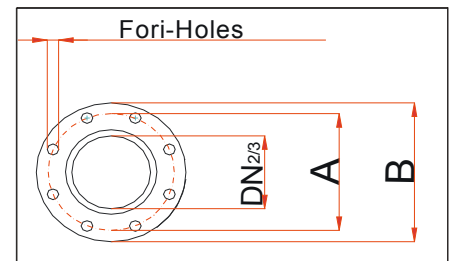

DIMENSIONI FLANGE UNI - UNI FLANGE DIMENSIONS

| TIPO - TYPE | DN 1 | DN 2/3 | A | B | Fori - Holes | | OPTIONAL | | | |
|--|------|--------|-----|-----|--------------|------|-----------|----------|---------------|--|
| | | | | | n° | φ mm | | | | |
| VT 80/2/200 C.367 VT 80/2/200 C.368 | 150 | 80 | 160 | 200 | 8 | 18 | P7-DN 150 | B5-DN 80 | DN 80 - PN 16 | |

CARATTERISTICHE TECNICHE - TECHNICAL FEATURES

| TIPO - TYPE | CAVO - CABLE H07 - RNF | MT | Sonde termiche | si | | | | |
|--|---------------------------|----|-----------------------|-----|--------------------|--------------------|--------------------|--------------------|
| | | | Thermal probes | yes | | | | |
| VT 80/2/200 C.367 VT 80/2/200 C.368 | (1) 10x2,5 φ 23 Y-Δ | 10 | Sonda di conduttività | si | Superiore Upper | Inferiore Lower | Superiore Upper | Inferiore Lower |
| | | | Conductivity probe | yes | MG1/55/G4 | MG1/40/G6 | NU 207 ECJC3 | 6312 2RS1 |

NOTE - NOTES :



Punto inferiore d'arresto nel caso di funzionamento automatico
Lowest shut-off point for automatic operation



Sommergenza minima nel caso di funzionamento continuo
Minimum covering for continuous operation

VM - VT 80/4/125 C. 341-342

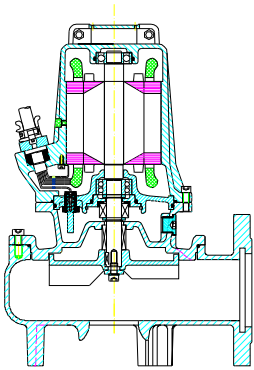

GIRANTE VORTEX
IMPELLER VORTEX



| | |
|------------------|------|
| PASSAGGIO LIBERO | 75mm |
| FREE PASSAGE | 75mm |

| | |
|---------------|----------|
| ALBERO MOTORE | AISI 420 |
| MOTOR SHAFT | AISI 420 |

Curve secondo ISO 9906. Livello 2
Curves as per ISO 9906. Grade 2

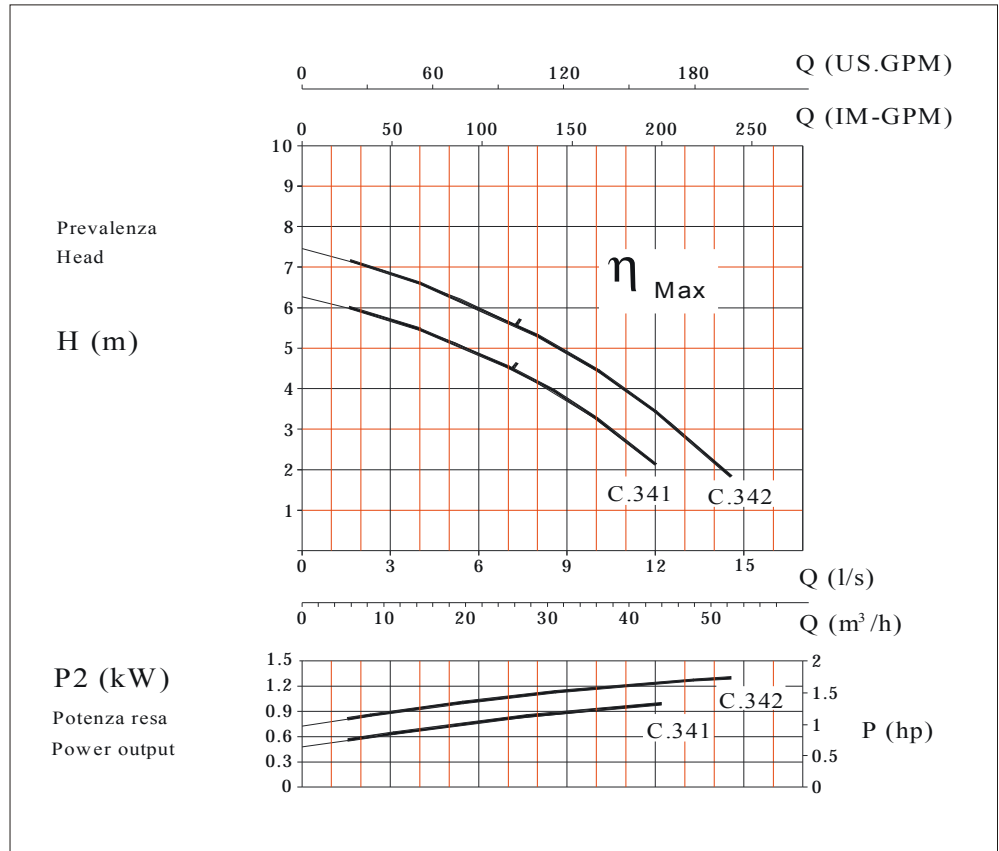

| Elettropompa Tipo Electric pump Type | Prevalenza - Head | | | | | | | | | | |
|---|--------------------|------|------|-----|-----|-----|-----|-----|-----|----|-----|
| | Hm bar | | | | | | | | | | |
| | 1 | 2 | 3 | 4 | 5 | 6 | 7 | 8 | 9 | 10 | 11 |
| | 0,1 | 0,2 | 0,3 | 0,4 | 0,5 | 0,6 | 0,7 | 0,8 | 0,9 | 1 | 1,1 |
| | Portata - Capacity | | | | | | | | | | |
| | Q (l/s) | | | | | | | | | | |
| VM - VT 80/4/125 C. 341 | | 12 | 10,5 | 8,5 | 5,5 | 2 | | | | | |
| VM - VT 80/4/125 C. 342 | | 14,5 | 13 | 11 | 9 | 6 | 2 | | | | |

Dati tecnici / Specifications

| | Mandata Delivery | kW | | r.p.m | Poles | Hz | Ampere | | | Cos ϕ |
|-------------------------|---------------------|-----|------|-------|-------|----|--------|----|----------|------------|
| | | P1 | P2 | 1/min | | | 1~ | | 400 V 3~ | |
| | | | | | | | 230 V | uf | | |
| VM - VT 80/4/125 C. 341 | DN2 80 | 1,5 | 1,1 | 1450 | 4 | 50 | 10,5 | 40 | 2,6 | 0,88 |
| VM - VT 80/4/125 C. 342 | | 1,8 | 1,25 | 1450 | 4 | 50 | 12,5 | 50 | 3,2 | 0,89 |

Dimensioni di ingombro dell'imballo
Overall dimensions of packing

| TIPO-TYPE | X | Y | Z | Kg |
|-------------------------|-----|-----|-----|----|
| VM - VT 80/4/125 C. 341 | 340 | 550 | 420 | 48 |
| VM - VT 80/4/125 C. 342 | 340 | 550 | 420 | 48 |

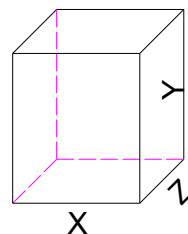

Dimensioni - Dimensions

VM - VT 80/4/125 C.341-342



INSTALLAZIONE FISSA
STATIONARY INSTALLATION

INSTALLAZIONE MOBILE
MOBILE INSTALLATION

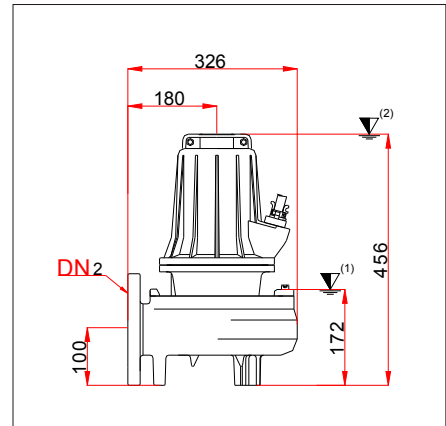
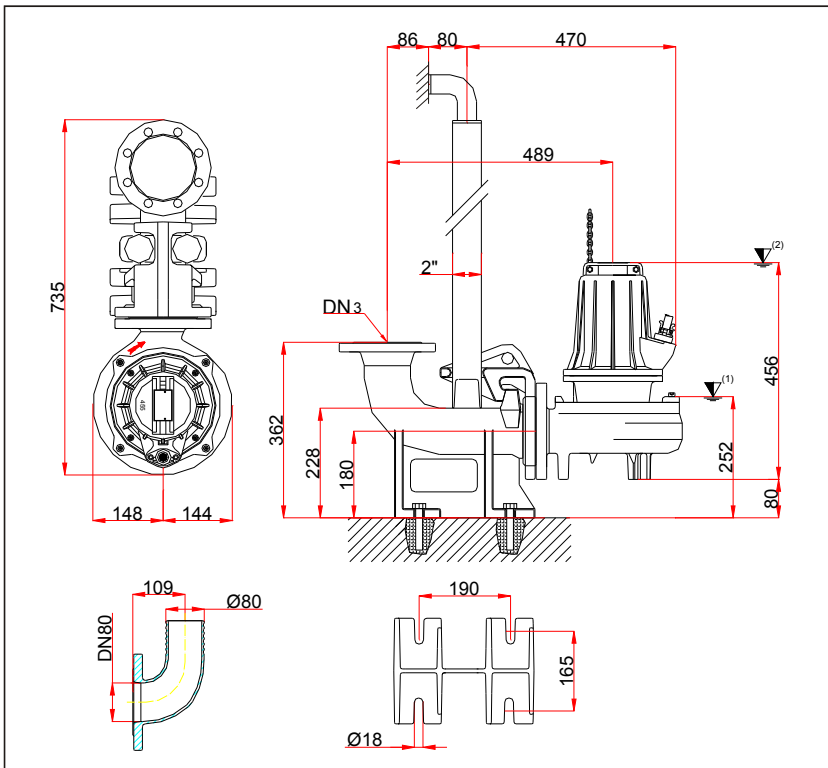

Dimensioni flange UNI
UNI flange dimensions

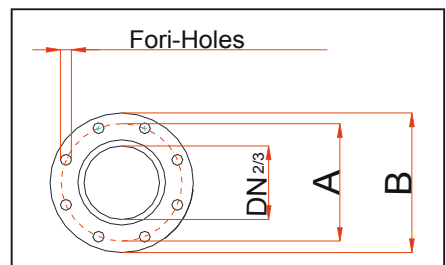

DIMENSIONI FLANGE UNI

| TIPO - TYPE | DN 2/3 | A | B | Fori - Holes | | OPTIONAL | | |
|--|--------|-----|-----|--------------|------|----------|---------------|--|
| | | | | n° | φ mm | | | |
| VM-VT 80/4/125 C.341 VM-VT 80/4/125 C.342 | 80 | 160 | 200 | 8 | 18 | B5-DN 80 | DN 80 - PN 16 | |

CARATTERISTICHE TECNICHE

| TIPO - TYPE | CAVO - CABLE H07 - RNF | MT | Sonde termiche | si | | | | |
|--|--------------------------------|----|-----------------------|-----|--------------------|--------------------|--------------------|--------------------|
| | | | Thermal probes | yes | Superiore Upper | Inferiore Lower | Superiore Upper | Inferiore Lower |
| VM-VT 80/4/125 C.341 VM-VT 80/4/125 C.342 | (1) 7x1,5 φ 15 AVV. DIRETTO | 10 | Sonda di conduttività | si | AR 20 | MG1S20/20-G26 | 6204 2Z | 3204 2Z |
| | | | Conductivity probe | yes | | | | |

NOTE - NOTES :



Punto inferiore d'arresto nel caso di funzionamento automatico
Lowest shut-off point for automatic operation



Sommergenza minima nel caso di funzionamento continuo
Minimum covering for continuous operation

VT 80/4/152 C. 343-344-345

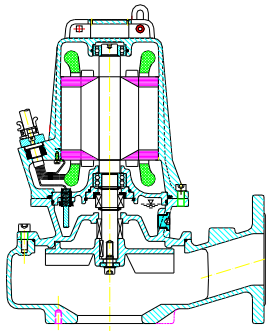

GIRANTE VORTEX
IMPELLER VORTEX



PASSAGGIO LIBERO 75mm
FREE PASSAGE 75mm

ALBERO MOTORE AISI 420
MOTOR SHAFT AISI 420

Curve secondo ISO 9906. Livello 2
Curves as per ISO 9906. Grade 2

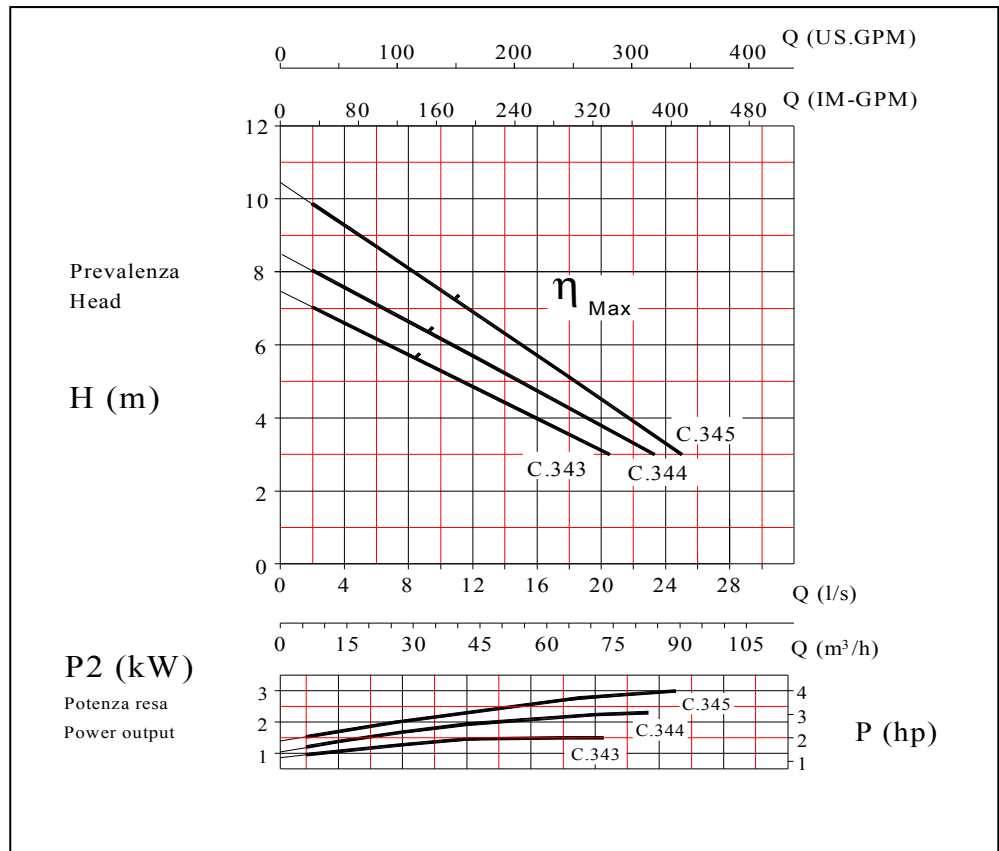

| Elettropompa Tipo Electric pump Type | Prevalenza - Head | | | | | | | | | | |
|---|--------------------|-----|-----|-----|-----|-----|-----|-----|-----|-----|-----|
| | Hm bar | | | | | | | | | | |
| | 2 | 3 | 4 | 5 | 6 | 7 | 8 | 9 | 10 | 11 | 12 |
| | 0,2 | 0,3 | 0,4 | 0,5 | 0,6 | 0,7 | 0,8 | 0,9 | 1 | 1,1 | 1,2 |
| | Portata - Capacity | | | | | | | | | | |
| | Q (l/s) | | | | | | | | | | |
| VT 80/4/152 C. 343 | | 21 | 16 | 11 | 5,4 | 2 | | | | | |
| VT 80/4/152 C. 344 | | 23 | 19 | 15 | 11 | 6,2 | 2 | | | | |
| VT 80/4/152 C. 345 | | 25 | 22 | 18 | 15 | 12 | 8 | 5 | 1,5 | | |

Dati tecnici / Specifications

| | Mandata Delivery | kW | | r.p.m | Poles | Ampere | Hz | Cos j |
|--------------------|---------------------|-----|-----|-------|-------|------------|----|-------|
| | | P1 | P2 | 1/min | | Trifase 3~ | | |
| | | | | | | 400V | | |
| VT 80/4/152 C. 343 | DN2 80 | 2,3 | 1,5 | 1450 | 4 | 4,1 | 50 | 0,84 |
| VT 80/4/152 C. 344 | | 3,1 | 2,2 | 1450 | 4 | 5,2 | 50 | 0,87 |
| VT 80/4/152 C. 345 | | 3,9 | 3 | 1450 | 4 | 6,8 | 50 | 0,86 |

**Dimensioni di ingombro dell'imballo
Overall dimensions of packing**

| TIPO-TYPE | X | Y | Z | Kg |
|--------------------|-----|-----|-----|----|
| VT 80/4/152 C. 343 | 340 | 550 | 420 | 65 |
| VT 80/4/152 C. 344 | 340 | 550 | 420 | 66 |
| VT 80/4/152 C. 345 | 340 | 550 | 420 | 69 |

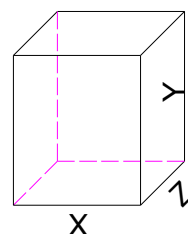

Dimensioni - Dimensions

VT 80/4/152 C.343-344-345



INSTALLAZIONE FISSA
STATIONARY INSTALLATION

INSTALLAZIONE MOBILE
MOBILE INSTALLATION

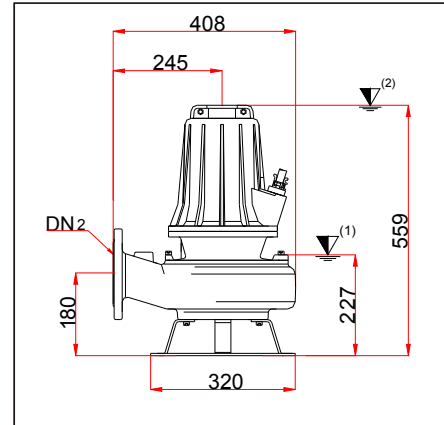
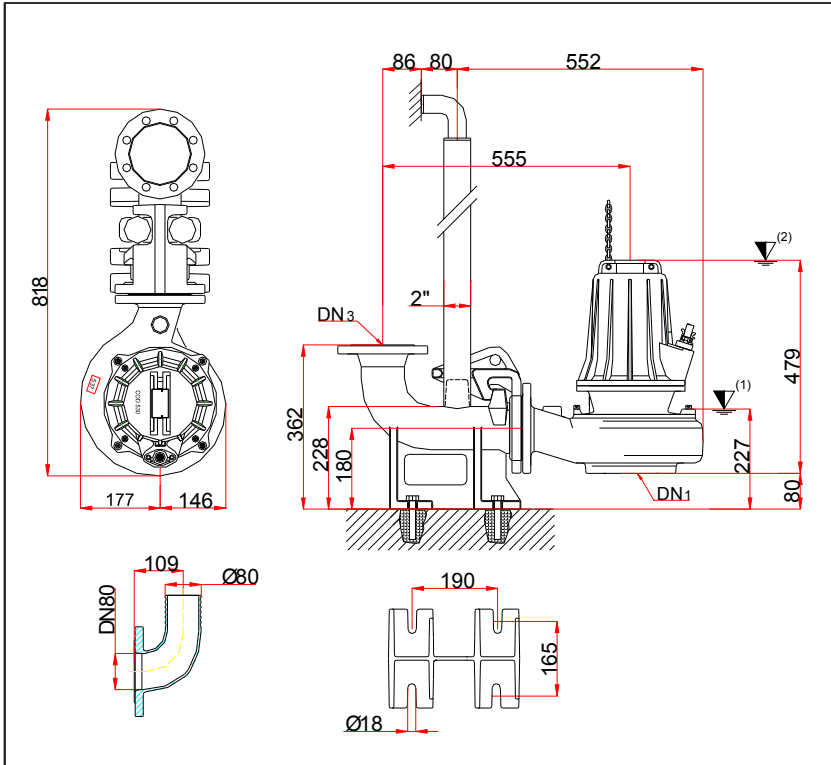

Dimensioni flange UNI
UNI flange dimensions

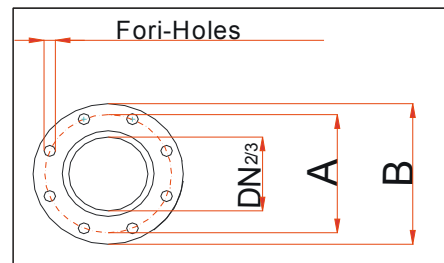

DIMENSIONI FLANGE UNI - UNI FLANGE DIMENSIONS

| TIPO - TYPE | DN 1 | DN 2/3 | A | B | Fori - Holes | | OPTIONAL | | | |
|---|------|--------|-----|-----|--------------|------|----------|----------|---------------|--|
| | | | | | n° | φ mm | | | | |
| VT 80/4/152 C.343 VT 80/4/152 C.344 VT 80/4/152 C.345 | 80 | 80 | 160 | 200 | 8 | 18 | P5-DN 80 | B5-DN 80 | DN 80 - PN 16 | |

CARATTERISTICHE TECNICHE - TECHNICAL FEATURES

| TIPO - TYPE | CAVO - CABLE H07 - RNF | MT | Sonde termiche | si | | | | |
|--|--------------------------------|----|-----------------------|-----|-----------|-------------|-----------|-----------|
| | | | Thermal probes | yes | | | | |
| VT 80-4-152 C. 343 VT 80-4-152 C. 344 VT 80-4-152 C. 345 | (1) 7x1,5 φ 15 AVV. DIRETTO | 10 | Sonda di conduttività | si | Superiore | Inferiore | Superiore | Inferiore |
| | | | Conductivity probe | yes | AR 25 | MG1/25 - G6 | 6205 2Z | 3205 2Z |

NOTE - NOTES :



Punto inferiore d'arresto nel caso di funzionamento automatico
Lowest shut-off point for automatic operation



Sommergenza minima nel caso di funzionamento continuo
Minimum covering for continuous operation

VT 100/4/152 C. 349-350

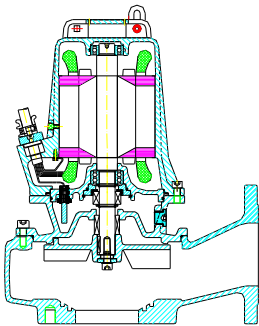

GIRANTE VORTEX
IMPELLER VORTEX



| | |
|------------------|------|
| PASSAGGIO LIBERO | 80mm |
| FREE PASSAGE | 80mm |

| | |
|---------------|----------|
| ALBERO MOTORE | AISI 420 |
| MOTOR SHAFT | AISI 420 |

Curve secondo ISO 9906. Livello 2
Curves as per ISO 9906. Grade 2

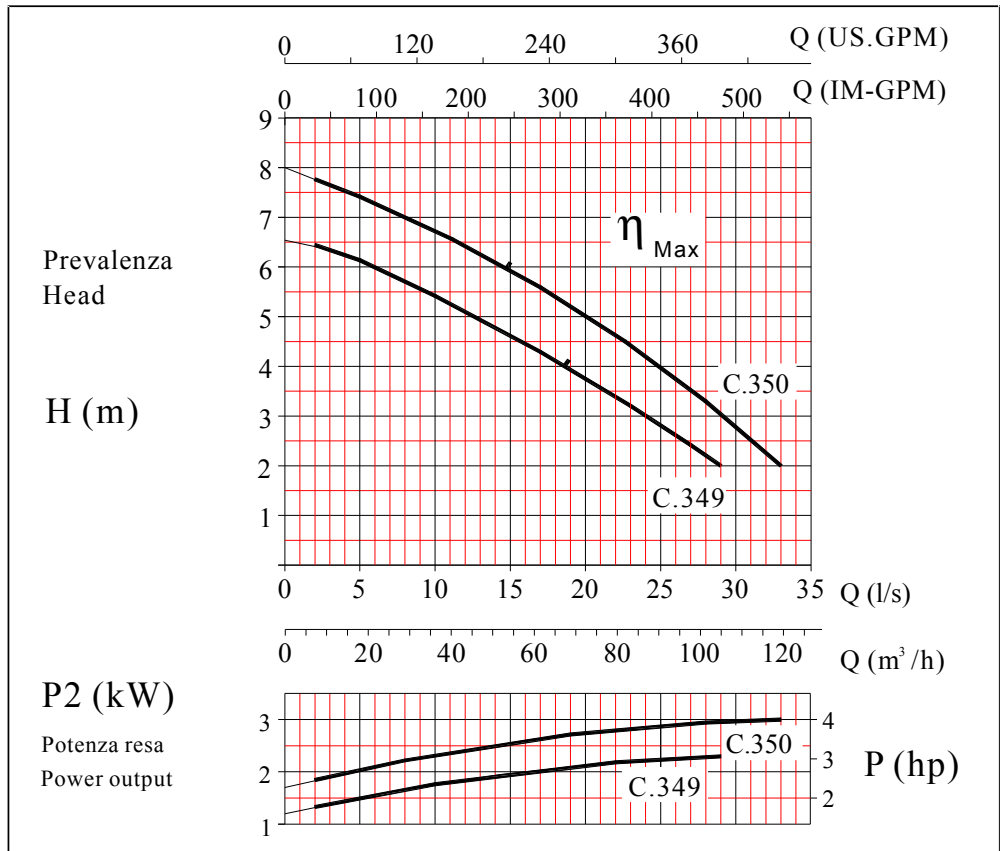

| Elettropompa Tipo Electric pump Type | Prevalenza - Head | | | | | | | | | | |
|---|-------------------|-----|-----|------|------|-----|-----|-----|-----|----|-----|
| | Hm bar | | | | | | | | | | |
| | 1 | 2 | 3 | 4 | 5 | 6 | 7 | 8 | 9 | 10 | 11 |
| | 0,1 | 0,2 | 0,3 | 0,4 | 0,5 | 0,6 | 0,7 | 0,8 | 0,9 | 1 | 1,1 |
| Portata - Capacity | | | | | | | | | | | |
| | Q (l/s) | | | | | | | | | | |
| VT 100/4/152 C. 349 | | 29 | 24 | 18,5 | 12,5 | 6 | | | | | |
| VT 100/4/152 C. 350 | | 33 | 29 | 25 | 20 | 15 | 8 | | | | |

Dati tecnici / Specifications

| | Mandata Delivery | kW | | r.p.m | Poles | Ampere | Hz | Cos j |
|---------------------|---------------------|-----|-----|-------|-------|------------|----|-------|
| | | P1 | P2 | 1/min | | Trifase 3~ | | |
| | | | | | | 400V | | |
| VT 100/4/152 C. 349 | DN2 100 | 3,1 | 2,2 | 1450 | 4 | 5,2 | 50 | 0,87 |
| VT 100/4/152 C. 350 | | 4,2 | 3 | 1450 | 4 | 7,1 | 50 | 0,84 |

Dimensioni di ingombro dell'imballo
Overall dimensions of packing

| TIPO-TYPE | X | Y | Z | Kg |
|---------------------|-----|-----|-----|------|
| VT 100/4/152 C. 349 | 400 | 620 | 465 | 70.5 |
| VT 100/4/152 C. 350 | 400 | 620 | 465 | 73.5 |

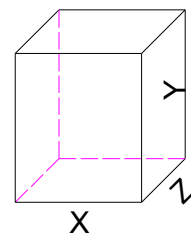

Dimensioni - Dimensions

VT 100/4/152 C.349-350



INSTALLAZIONE FISSA
STATIONARY INSTALLATION

INSTALLAZIONE MOBILE
MOBILE INSTALLATION

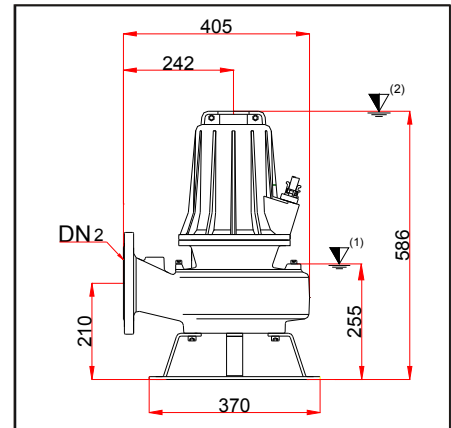
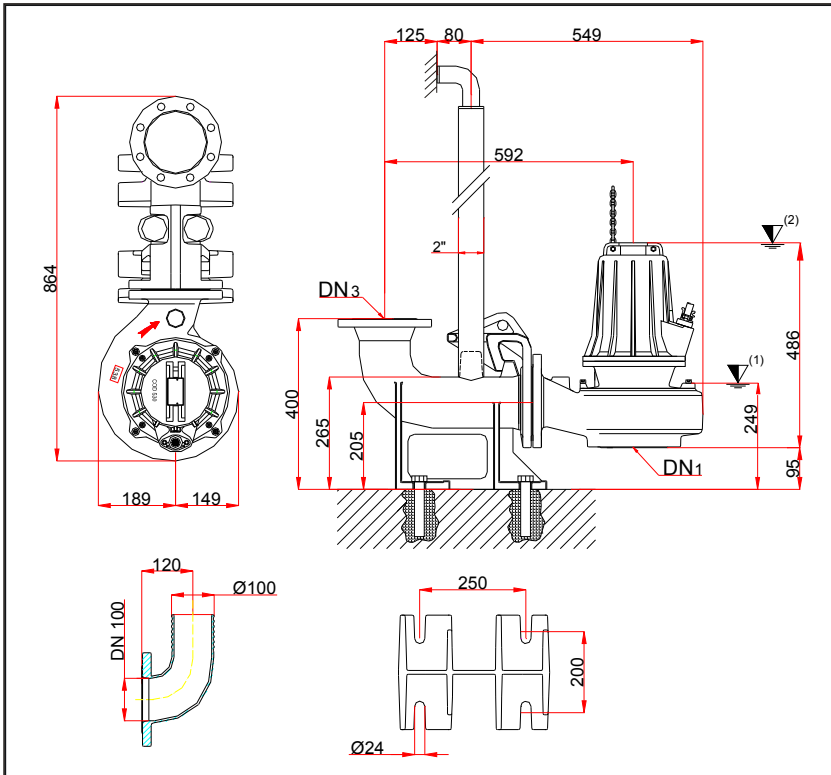

Dimensioni flange UNI
UNI flange dimensions

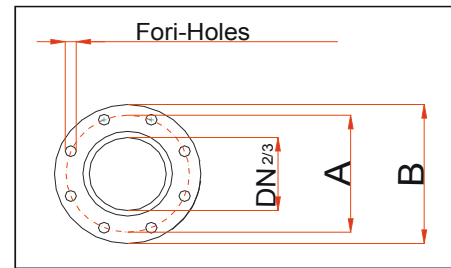

DIMENSIONI FLANGE UNI - UNI FLANGE DIMENSIONS

| TIPO - TYPE | DN 1 | DN 2/3 | A | B | Fori - Holes | | OPTIONAL | | | |
|--|------|--------|-----|-----|--------------|------|-----------|-----------|----------------|--|
| | | | | | n° | φ mm | | | | |
| VT 100/4/152 C.349 VT 100/4/152 C.350 | 100 | 100 | 180 | 220 | 8 | 18 | P6-DN 100 | B6-DN 100 | DN 100 - PN 16 | |

CARATTERISTICHE TECNICHE - TECHNICAL FEATURES

| TIPO - TYPE | CAVO - CABLE H07 - RNF | MT | Sonde termiche | si | | | | |
|--|--------------------------------|----|-----------------------|-----|-----------|-------------|-----------|-----------|
| | | | Thermal probes | yes | | | | |
| VT 100/4/152 C.349 VT 100/4/152 C.350 | (1) 7x1,5 φ 15 AVV. DIRETTO | 10 | Sonda di conduttività | si | Superiore | Inferiore | Superiore | Inferiore |
| | | | Conductivity probe | yes | Upper | Lower | Upper | Lower |
| | | | | | AR 25 | MG1/25 - G6 | 6205 2Z | 3205 2Z |

NOTE - NOTES :



Punto inferiore d'arresto nel caso di funzionamento automatico
Lowest shut-off point for automatic operation



Sommergenza minima nel caso di funzionamento continuo
Minimum covering for continuous operation

VT 100/4/173 C. 355-356

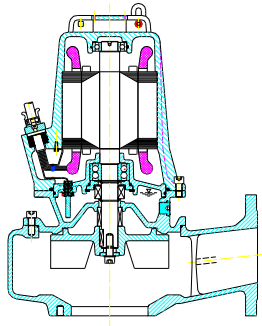

GIRANTE VORTEX
IMPELLER VORTEX



| | |
|------------------|------|
| PASSAGGIO LIBERO | 90mm |
| FREE PASSAGE | 90mm |

| | |
|---------------|----------|
| ALBERO MOTORE | AISI 420 |
| MOTOR SHAFT | AISI 420 |

Curve secondo ISO 9906. Livello 2
Curves as per ISO 9906. Grade 2

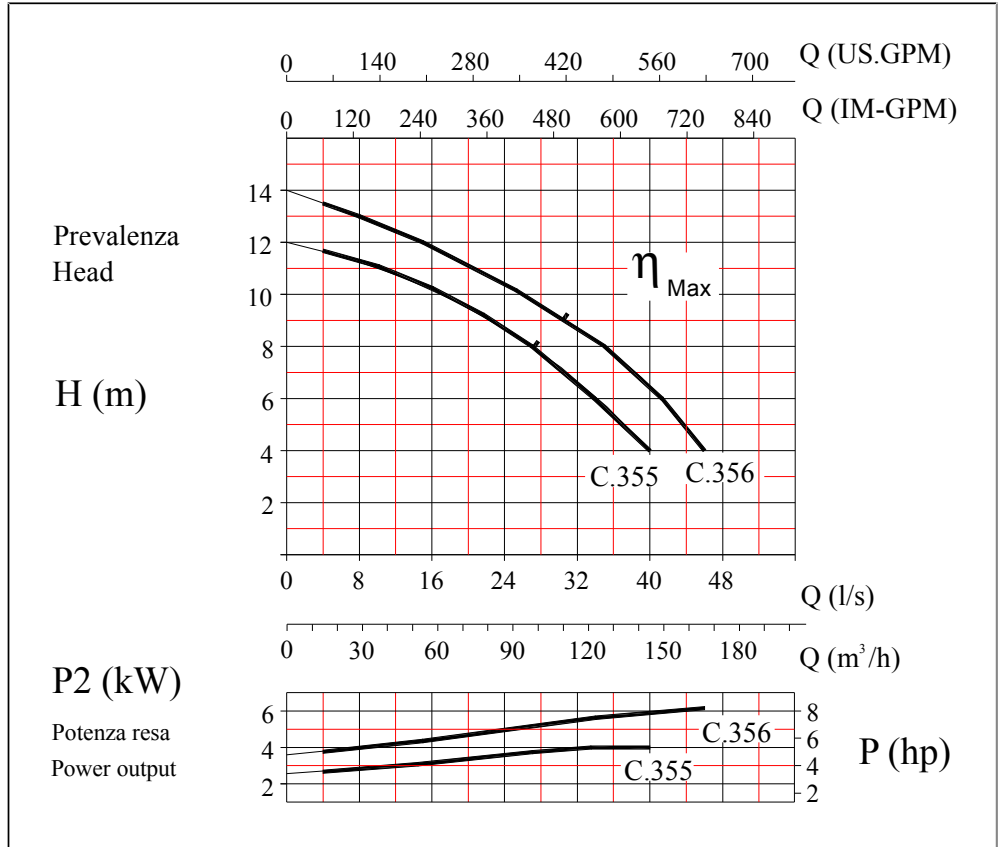

| Elettropompa Tipo Electric pump Type | Prevalenza - Head | | | | | | | | | | |
|---|--------------------|-----|------|-----|------|-----|----|-----|-----|-----|-----|
| | Hm bar | | | | | | | | | | |
| | 4 | 5 | 6 | 7 | 8 | 9 | 10 | 11 | 12 | 13 | 14 |
| | Portata - Capacity | | | | | | | | | | |
| | Q (l/s) | | | | | | | | | | |
| | 0,4 | 0,5 | 0,6 | 0,7 | 0,8 | 0,9 | 1 | 1,1 | 1,2 | 1,3 | 1,4 |
| VT 100/4/173 C. 355 | 40 | 36 | 33,5 | 30 | 27 | 22 | 17 | 10 | | | |
| VT 100/4/173 C. 356 | 46 | 44 | 41 | 38 | 34,5 | 31 | 25 | 20 | 15 | 8 | |

Dati tecnici / Specifications

| | Mandata Delivery | kW | | r.p.m | Poles | Ampere | Hz | Cos j |
|---------------------|---------------------|-----|----|-------|-------|------------|----|-------|
| | | P1 | P2 | 1/min | | Trifase 3~ | | |
| | | | | | | 400V | | |
| VT 100/4/173 C. 355 | DN2 100 | 5,4 | 4 | 1450 | 4 | 9 | 50 | 0,88 |
| VT 100/4/173 C. 356 | | 7,5 | 6 | 1450 | 4 | 12,4 | 50 | 0,87 |

Dimensioni di ingombro dell'imballo
Overall dimensions of packing

| TIPO-TYPE | X | Y | Z | Kg |
|---------------------|-----|-----|-----|----|
| VT 100/4/173 C. 355 | 400 | 620 | 465 | 95 |
| VT 100/4/173 C. 356 | 400 | 620 | 465 | 99 |

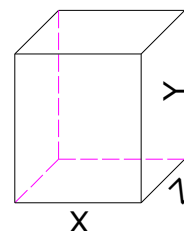

Dimensioni - Dimensions

VT 100/4/173 C. 355-356



INSTALLAZIONE FISSA
STATIONARY INSTALLATION

INSTALLAZIONE MOBILE
MOBILE INSTALLATION

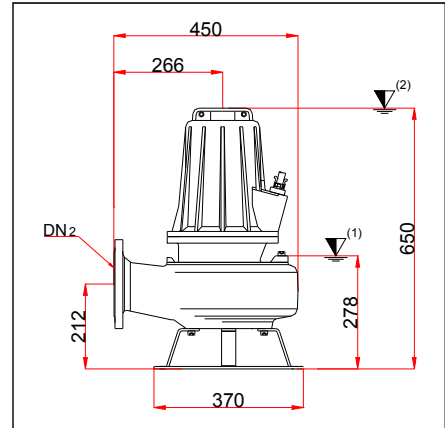
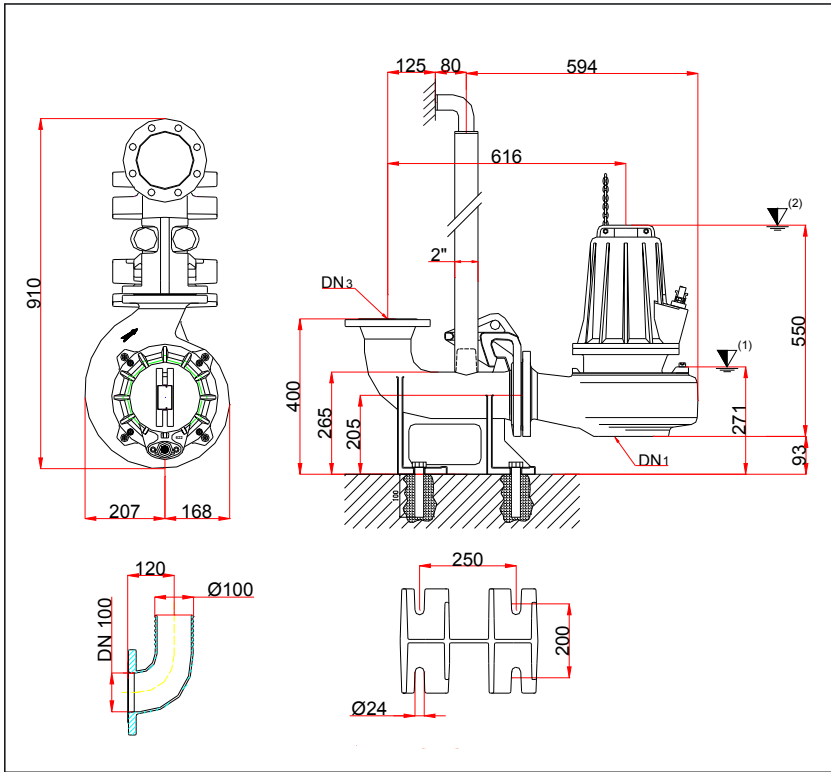

Dimensioni flange UNI
UNI flange dimensions

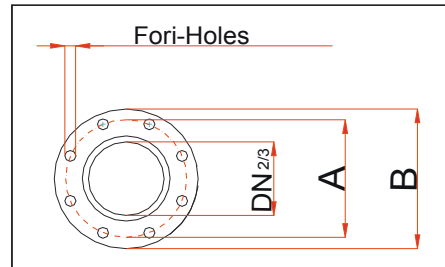

DIMENSIONI FLANGE UNI - UNI FLANGE DIMENSIONS

| TIPO - TYPE | DN ₁ | DN _{2/3} | A | B | Fori - Holes | | OPTIONAL | | | |
|--|-----------------|-------------------|-----|-----|--------------|------|-----------|-----------|----------------|--|
| | | | | | n° | φ mm | | | | |
| VT 100-4-173 C.355 VT 100-4-173 C.356 | 100 | 100 | 180 | 220 | 8 | 18 | P6-DN 100 | B6-DN 100 | DN 100 - PN 16 | |

CARATTERISTICHE TECNICHE - TECHNICAL FEATURES

| TIPO - TYPE | CAVO - CABLE H07 - RNF | MT | Sonde termiche | si | | | | |
|--|---------------------------|----|-----------------------|-----|-----------|-----------|-----------|-----------|
| | | | Thermal probes | yes | | | | |
| VT 100-4-173 C.355 VT 100-4-173 C.356 | (1) 10x1,5 φ 20 Y-Δ | 10 | Sonda di conduttività | si | Superiore | Inferiore | Superiore | Inferiore |
| | | | Conductivity probe | yes | AR 30 | MG1/30/G6 | 6206 2Z | 3306 2Z |

NOTE - NOTES :



Punto inferiore d'arresto nel caso di funzionamento automatico
Lowest shut-off point for automatic operation



Sommergenza minima nel caso di funzionamento continuo
Minimum covering for continuous operation

VT 100/4/200 C. 360-362-363

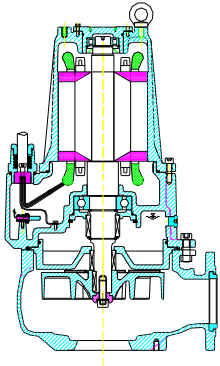

GIRANTE VORTEX
IMPELLER VORTEX



| | |
|------------------|------|
| PASSAGGIO LIBERO | 90mm |
| FREE PASSAGE | 90mm |

| | |
|---------------|----------|
| ALBERO MOTORE | AISI 420 |
| MOTOR SHAFT | AISI 420 |

Curve secondo ISO 9906. Livello 2
Curves as per ISO 9906. Grade 2

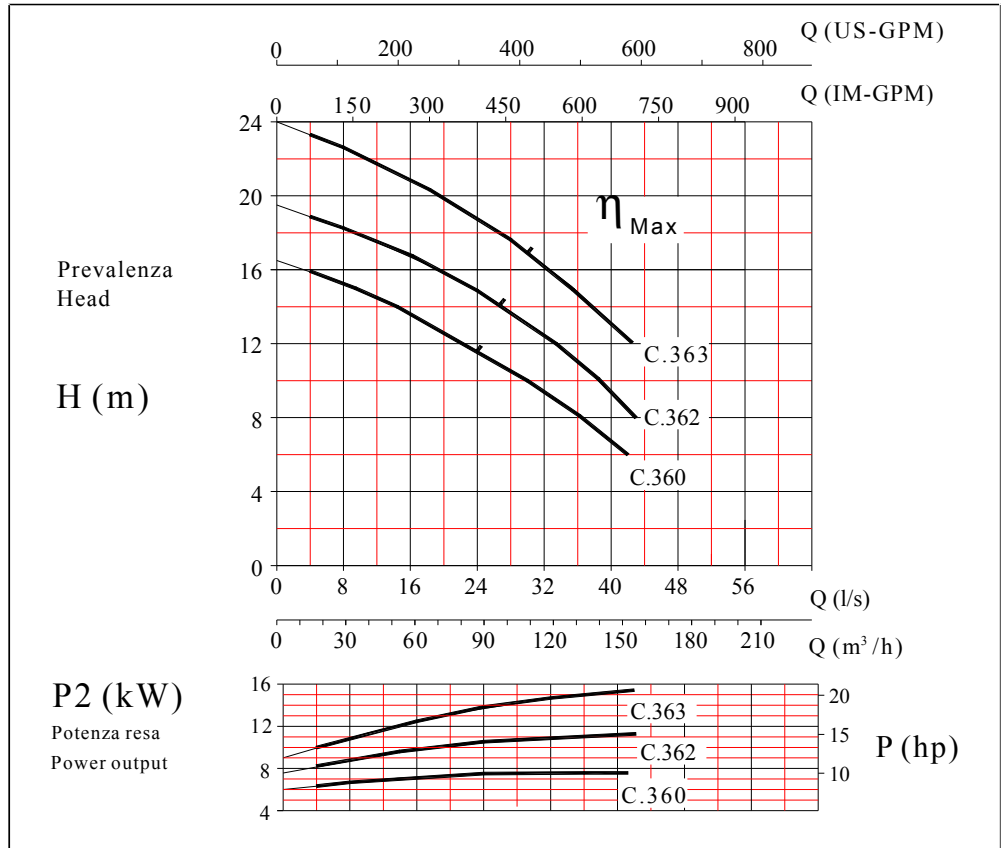

| Elettropompa Tipo Electric pump Type | Prevalenza - Head | | | | | | | | | | |
|---|--------------------|-----|-----|----|-----|-----|-----|-----|----|-----|-----|
| | Hm bar | | | | | | | | | | |
| | 4 | 6 | 8 | 10 | 12 | 14 | 16 | 18 | 20 | 22 | 24 |
| | 0,4 | 0,6 | 0,8 | 1 | 1,2 | 1,4 | 1,6 | 1,8 | 2 | 2,2 | 2,4 |
| | Portata - Capacity | | | | | | | | | | |
| | Q (l/s) | | | | | | | | | | |
| VT 100/4/200 C. 360 | | 42 | 36 | 30 | 22 | 14 | 4 | | | | |
| VT 100/4/200 C. 362 | | | 43 | 39 | 33 | 28 | 20 | 9 | | | |
| VT 100/4/200 C. 363 | | | | | 42 | 38 | 32 | 27 | 20 | 10 | |

Dati tecnici / Specifications

| | Mandata Delivery | kW | | r.p.m | Poles | Ampere | Hz | Cos j |
|---------------------|---------------------|------|------|-------|-------|------------|----|-------|
| | | P1 | P2 | 1/min | | Trifase 3~ | | |
| | | | | | | 400V | | |
| VT 100/4/200 C. 360 | DN2 100 | 10,2 | 7,5 | 1450 | 4 | 18,8 | 50 | 0,82 |
| VT 100/4/200 C. 362 | | 15,1 | 11,4 | 1450 | 4 | 22,5 | 50 | 0,81 |
| VT 100/4/200 C. 363 | | 19,8 | 15,3 | 1450 | 4 | 28,7 | 50 | 0,80 |

Dimensioni di ingombro dell'imballo
Overall dimensions of packing

| TIPO-TYPE | X | Y | Z | Kg |
|---------------------|-----|-----|-----|-----|
| VT 100/4/200 C. 360 | 550 | 860 | 645 | 194 |
| VT 100/4/200 C. 362 | 550 | 860 | 645 | 196 |
| VT 100/4/200 C. 363 | 550 | 860 | 645 | 205 |

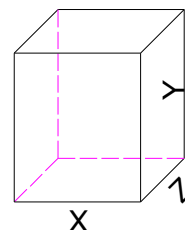

VT 100/4/200 C.360-362-363

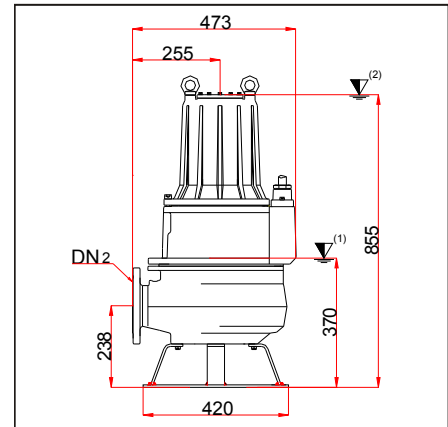
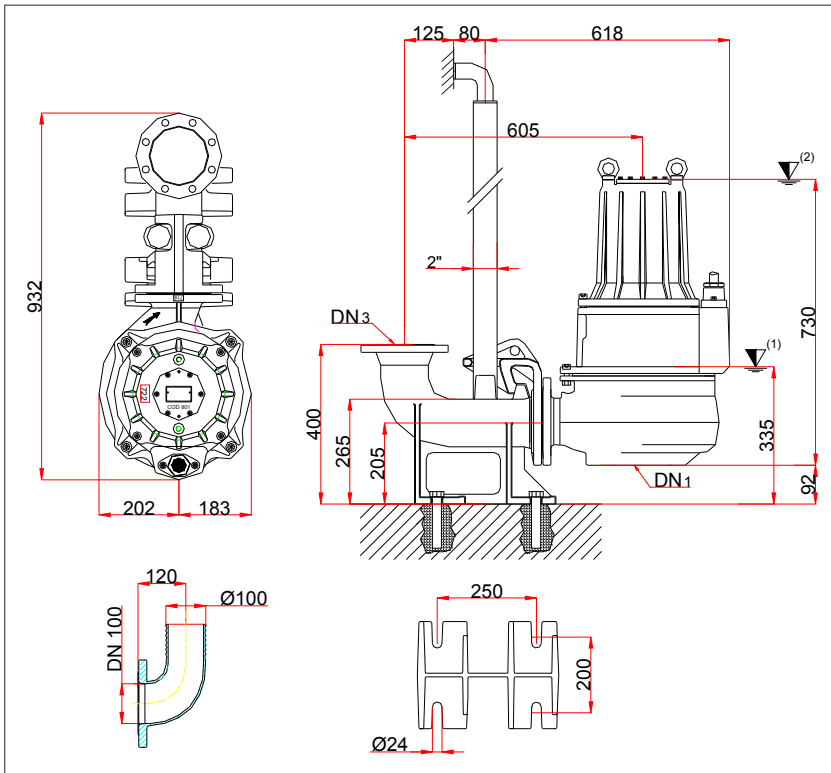
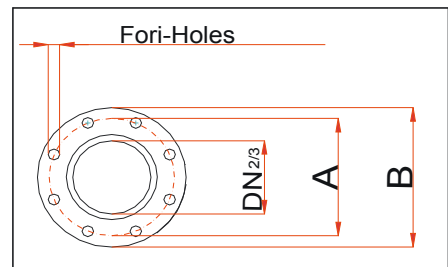
INSTALLAZIONE FISSA
STATIONARY INSTALLATION
INSTALLAZIONE MOBILE
MOBILE INSTALLATION

Dimensioni flange UNI
UNI flange dimensions

DIMENSIONI FLANGE UNI - UNI FLANGE DIMENSIONS

| TIPO - TYPE | DN ₁ | DN _{2/3} | A | B | Fori - Holes | | OPTIONAL | | | |
|--|-----------------|-------------------|-----|-----|--------------|------|-----------|-----------|----------------|--|
| | | | | | n° | φ mm | | | | |
| VT 100/4/200 C.360 VT 100/4/200 C.362 VT 100/4/200 C.363 | 150 | 100 | 180 | 220 | 8 | 18 | P7-DN 150 | B6-DN 100 | DN 100 - PN 16 | |

CARATTERISTICHE TECNICHE - TECHNICAL FEATURES

| TIPO - TYPE | CAVO - CABLE H07 - RNF | MT | Sonde termiche | si | | | | |
|--|---------------------------|----|-----------------------|-----|--------------------|--------------------|--------------------|--------------------|
| | | | Thermal probes | yes | | | | |
| VT 100/4/200 C.360 VT 100/4/200 C.362 VT 100/4/200 C.363 | (1) 10x2,5 φ 23 Y-Δ | 10 | Sonda di conduttività | si | Superiore Upper | Inferiore Lower | Superiore Upper | Inferiore Lower |
| | | | Conductivity probe | yes | MG1/55/G4 | MG1/40/G6 | NU 207 ECJ3 | 6312 2RS1 |

NOTE - NOTES :

Punto inferiore d'arresto nel caso di funzionamento automatico
Lowest shut-off point for automatic operation

Sommergenza minima nel caso di funzionamento continuo
Minimum covering for continuous operation

VT 100/4/240 C. 375-380

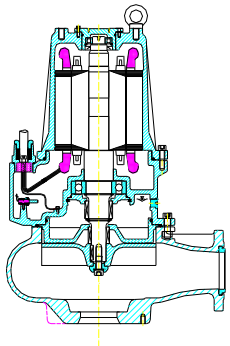

GIRANTE VORTEX
IMPELLER VORTEX



| | |
|------------------|------|
| PASSAGGIO LIBERO | 90mm |
| FREE PASSAGE | 90mm |

| | |
|---------------|----------|
| ALBERO MOTORE | AISI 420 |
| MOTOR SHAFT | AISI 420 |

Curve secondo ISO 9906. Livello 2
Curves as per ISO 9906. Grade 2

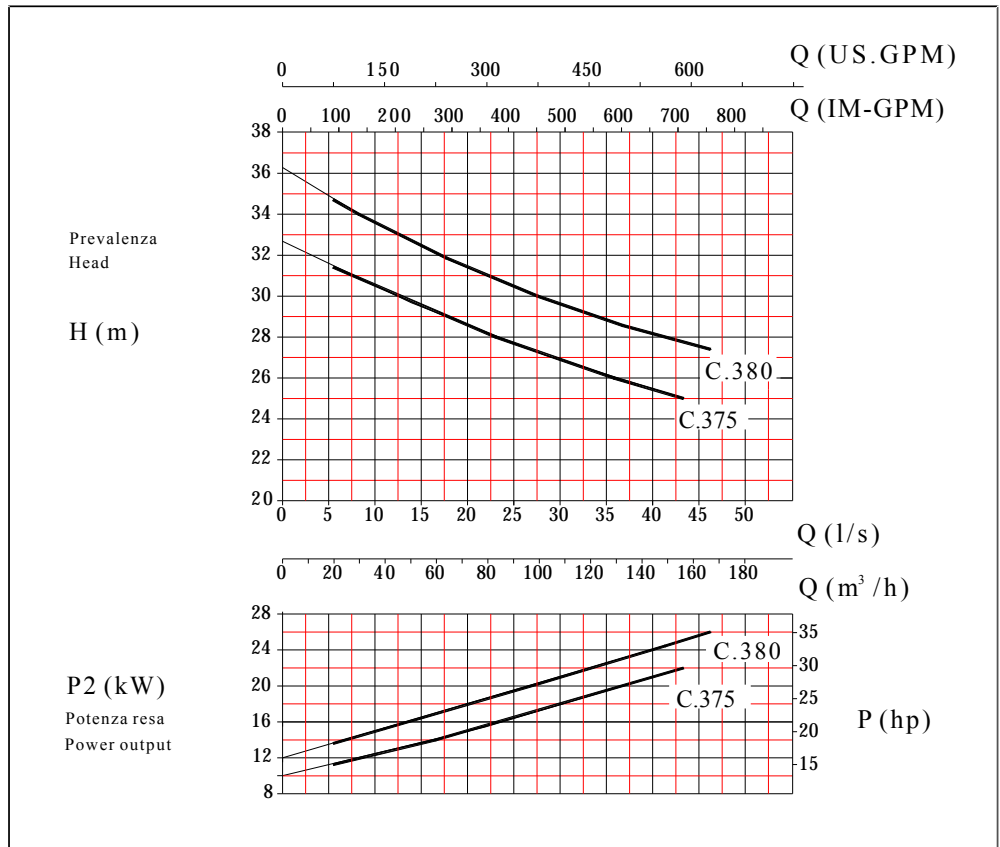

| Elettropompa Tipo Electric pump Type | Prevalenza - Head | | | | | | | | | | |
|---|--------------------|-----|-----|------|------|-----|-----|-----|-----|----|-----|
| | Hm bar | | | | | | | | | | |
| | 22 | 24 | 26 | 28 | 30 | 32 | 34 | 36 | 38 | 40 | 42 |
| | 2,2 | 2,4 | 2,6 | 2,8 | 3 | 3,2 | 3,4 | 3,6 | 3,8 | 4 | 4,2 |
| | Portata - Capacity | | | | | | | | | | |
| | Q (l/s) | | | | | | | | | | |
| VT 100/4/240 C. 375 | | | 36 | 22,5 | 12,5 | 3 | | | | | |
| VT 100/4/240 C. 380 | | | | 41 | 27,5 | 17 | 8 | | | | |

Dati tecnici / Specifications

| | Mandata Delivery | kW | | r.p.m | Poles | Ampere | Hz | Cos j |
|---------------------|---------------------|------|----|-------|-------|------------|----|-------|
| | | P1 | P2 | 1/min | | Trifase 3~ | | |
| | | | | | | 400V | | |
| VT 100/4/240 C. 375 | DN2 100 | 29,3 | 22 | 1450 | 4 | 43 | 50 | 0,80 |
| VT 100/4/240 C. 380 | | 34,6 | 26 | 1450 | 4 | 50 | 50 | 0,79 |

Dimensioni di ingombro dell'imballo
Overall dimensions of packing

| TIPO-TYPE | X | Y | Z | Kg |
|---------------------|-----|-----|-----|-----|
| VT 100/4/240 C. 375 | 550 | 860 | 645 | 288 |
| VT 100/4/240 C. 380 | 550 | 860 | 645 | 295 |

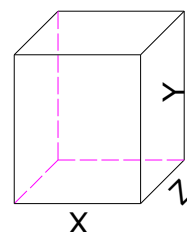

Dimensioni - Dimensions

VT 100/4/240 C.375-380



INSTALLAZIONE FISSA
STATIONARY INSTALLATION

INSTALLAZIONE MOBILE
MOBILE INSTALLATION

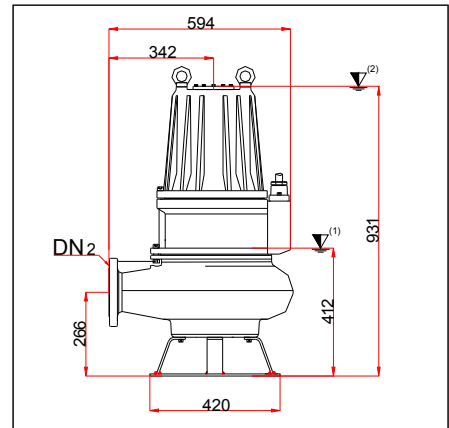
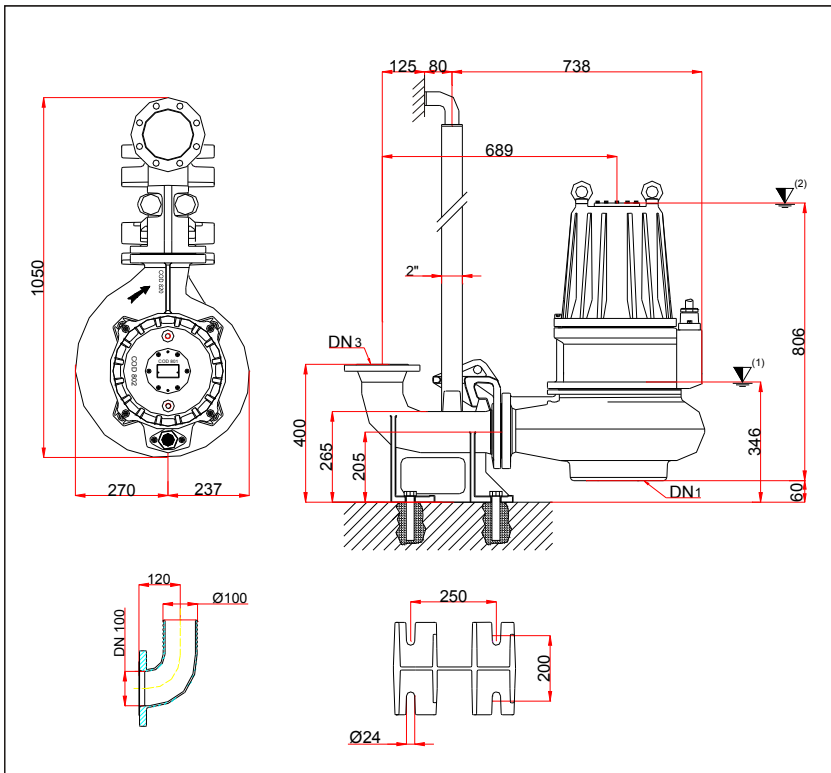

Dimensioni flange UNI
UNI flange dimensions

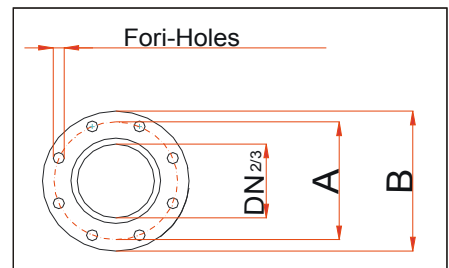

DIMENSIONI FLANGE UNI - UNI FLANGE DIMENSIONS

| TIPO - TYPE | DN 1 | DN 2/3 | A | B | Fori - Holes | | OPTIONAL | | | |
|--|------|--------|-----|-----|--------------|------|-----------|-----------|----------------|--|
| | | | | | n° | φ mm | | | | |
| VT 100-4-240 C.375 VT 100-4-240 C.380 | 150 | 100 | 180 | 220 | 8 | 18 | P7-DN 150 | B6-DN 100 | DN 100 - PN 16 | |

CARATTERISTICHE TECNICHE - TECHNICAL FEATURES

| TIPO - TYPE | CAVO - CABLE H07 - RNF | MT | Sonde termiche | si | | | | |
|--|---------------------------|----|-----------------------|-----|--------------------|--------------------|--------------------|--------------------|
| | | | Thermal probes | yes | | | | |
| VT 100-4-240 C.375 VT 100-4-240 C.380 | (1) 7x4+3x1 φ20,5 Y-Δ | 10 | Sonda di conduttività | si | Superiore Upper | Inferiore Lower | Superiore Upper | Inferiore Lower |
| | | | Conductivity probe | yes | MG1/55/G4 | MG1/40/G6 | NU 207 ECJ C3 | 6314 2RS1 |

NOTE - NOTES :



Punto inferiore d'arresto nel caso di funzionamento automatico
Lowest shut-off point for automatic operation



Sommergenza minima nel caso di funzionamento continuo
Minimum covering for continuous operation

VT 150/4/340 C. 385-390-395

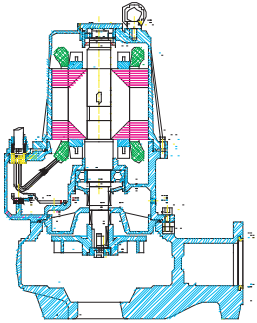

GIRANTE VORTEX
IMPELLER VORTEX



| | |
|------------------|-------|
| PASSAGGIO LIBERO | 130mm |
| FREE PASSAGE | 130mm |

| | |
|---------------|----------|
| ALBERO MOTORE | AISI 420 |
| MOTOR SHAFT | AISI 420 |

Curve secondo ISO 9906. Livello 2
Curves as per ISO 9906. Grade 2

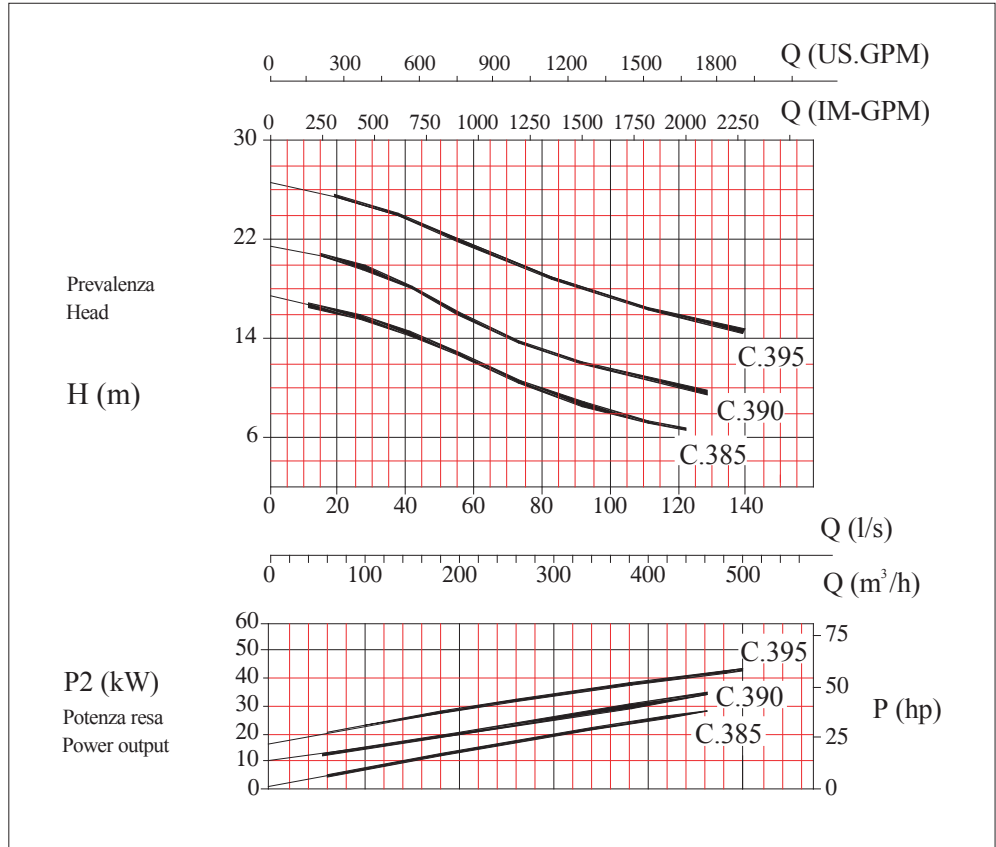

| Elettropompa Tipo Electric pump Type | Prevalenza - Head | | | | | | | | | | |
|---|--------------------|-----|-----|-----|-----|-----|-----|----|-----|-----|-----|
| | Hm bar | | | | | | | | | | |
| | 6 | 8 | 10 | 12 | 14 | 16 | 18 | 20 | 22 | 24 | 26 |
| | 0,6 | 0,8 | 1 | 1,2 | 1,4 | 1,6 | 1,8 | 2 | 2,2 | 2,4 | 2,6 |
| | Portata - Capacity | | | | | | | | | | |
| | Q (l/s) | | | | | | | | | | |
| VT 150/4/340 C. 385 | 130 | 105 | 80 | 63 | 45 | 20 | | | | | |
| VT 150/4/340 C. 390 | | | 125 | 95 | 70 | 55 | 42 | 25 | | | |
| VT 150/4/340 C. 395 | | | | | 150 | 120 | 95 | 72 | 55 | 40 | 10 |

Dati tecnici / Specifications

| | Mandata Delivery | kW | | r.p.m | Poles | Ampere | Hz | Cos φ |
|---------------------|------------------|------|------|-------|-------|--------------------|----|-------|
| | | P1 | P2 | 1/min | | Trifase 3~ 400V | | |
| | | | | | | | | |
| VT 150/4/340 C. 385 | DN2 150 | 36,8 | 29,5 | 1450 | 4 | 56 | 50 | 0,81 |
| VT 150/4/340 C. 390 | | 46,2 | 37 | 1450 | 4 | 68 | 50 | 0,80 |
| VT 150/4/340 C. 395 | | 53,8 | 43 | 1450 | 4 | 81 | 50 | 0,79 |

Dimensioni di ingombro dell'imballo
Overall dimensions of packing

| TIPO-TYPE | X | Y | Z | Kg |
|---------------------|-----|-----|-----|-----|
| VT 150/4/340 C. 385 | 540 | 855 | 639 | 530 |
| VT 150/4/340 C. 390 | 540 | 855 | 639 | 570 |
| VT 150/4/340 C. 395 | 540 | 855 | 639 | 585 |

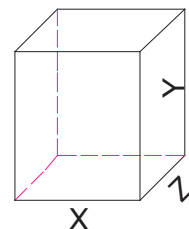

Dimensioni - Dimensions

VT 150/4/340 C.385-390-395



INSTALLAZIONE FISSA
STATIONARY INSTALLATION

INSTALLAZIONE MOBILE
MOBILE INSTALLATION

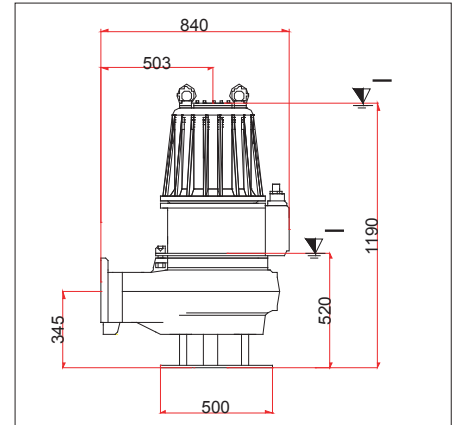
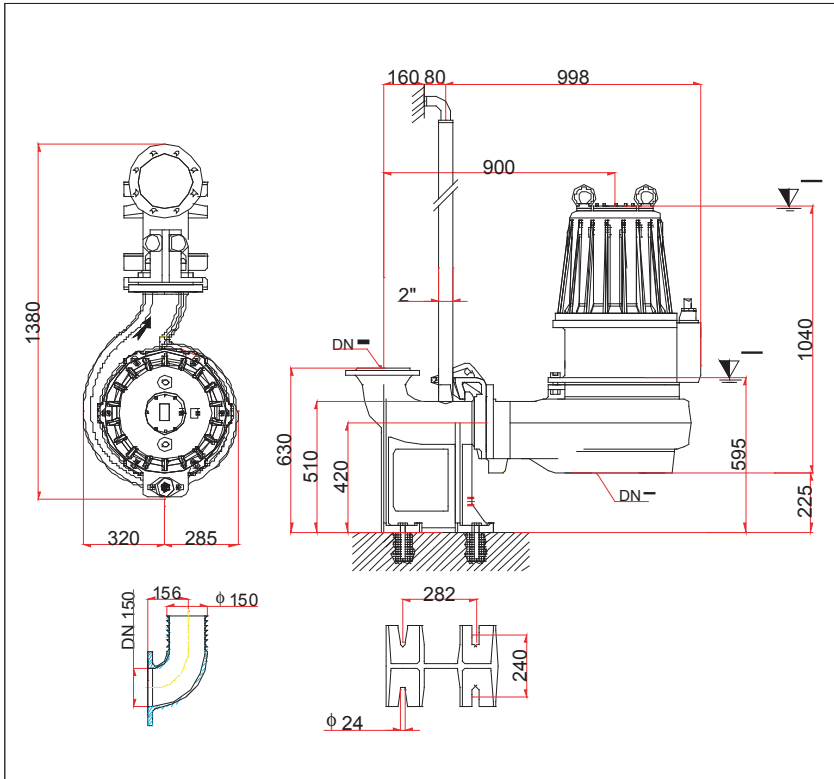

Dimensioni flange UNI
UNI flange dimensions

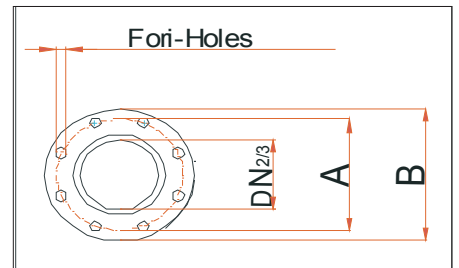

DIMENSIONI FLANGE UNI - UNI FLANGE DIMENSIONS

| TIPO - TYPE | DN 1 | DN 2/3 | A | B | Fori - Holes | | OPTIONAL | | | |
|--|------|--------|-----|-----|--------------|------|----------|--|----------------|--|
| | | | | | n° | φ mm | | | DN 150 - PN 16 | |
| VT 150/4/340 C.385 VT 150/4/340 C.390 VT 150/4/340 C.395 | 150 | 150 | 240 | 285 | 8 | 22 | | | DN 150 - PN 16 | |

CARATTERISTICHE TECNICHE - TECHNICAL FEATURES

| TIPO - TYPE | CAVO - CABLE H07 - RNF | MT | Sonde termiche Thermal probes | | | | | | |
|--|---------------------------|----|---|-----------|-----------|--------------------|--------------------|--------------------|--------------------|
| | | | | si yes | | | | | |
| VT 150/4/340 C.385 VT 150/4/340 C.390 VT 150/4/340 C.395 | (1) 7x10+5x1 φ 29 Y-△ | 10 | Sonda di conduttività Conductivity probe | | si yes | Superiore Upper | Inferiore Lower | Superiore Upper | Inferiore Lower |
| | | | | | | MG1/65/G6 | MG1/55/G4 | NU 211 ECJ C3 | 6316 2RS1 |

NOTE - NOTES :



Punto inferiore d'arresto nel caso di funzionamento automatico
Lowest shut-off point for automatic operation



Sommergenza minima nel caso di funzionamento continuo
Minimum covering for continuous operation

GM-GT 32/2/110 C. 149

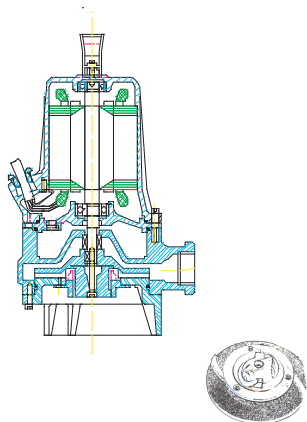

GIRANTE CON TRITURATORE
IMPELLER FOR GRINDER

| | |
|------------------|-----|
| PASSAGGIO LIBERO | 6mm |
| FREE PASSAGE | 6mm |

| | |
|---------------|----------|
| ALBERO MOTORE | AISI 420 |
| MOTOR SHAFT | AISI 420 |

Curve secondo ISO 9906. Livello 2
Curves as per ISO 9906. Grade 2

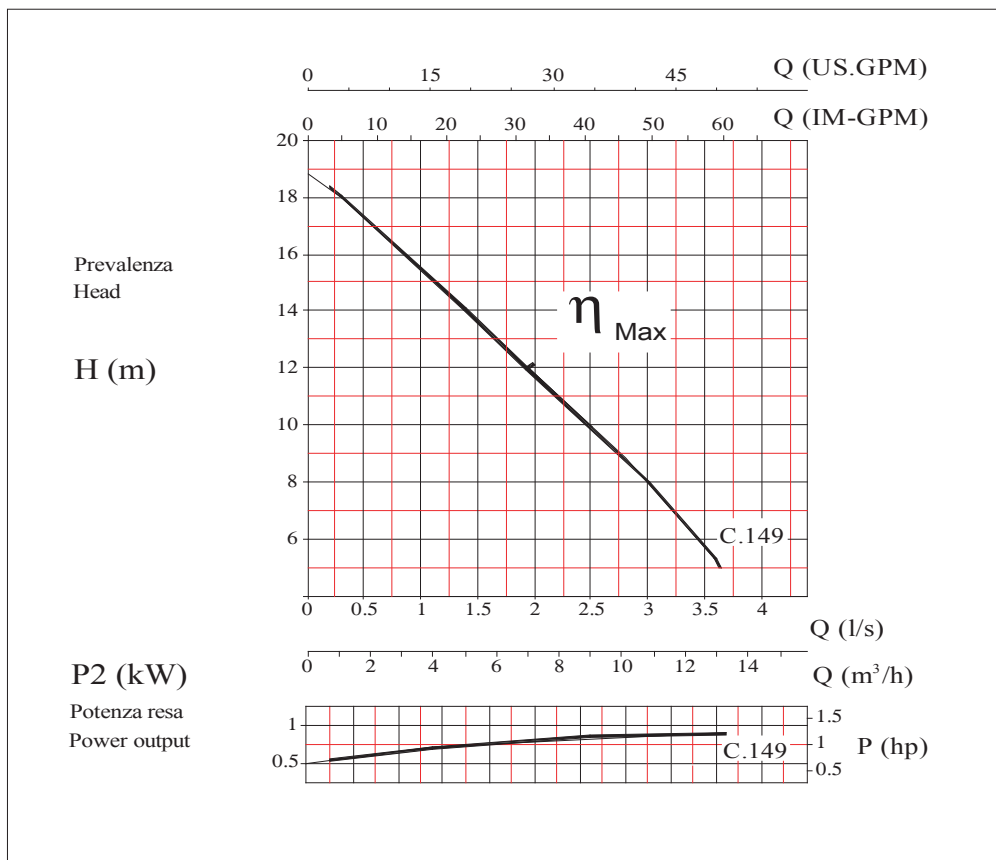

| Elettropompa Tipo Electric pump Type | Prevalenza - Head | | | | | | | | | | |
|---|--------------------|-----|-----|-----|-----|-----|-----|------|----|-----|-----|
| | Hm bar | | | | | | | | | | |
| | 4 | 5 | 6 | 10 | 12 | 14 | 16 | 18 | 20 | 22 | 24 |
| | 0,4 | 0,5 | 0,6 | 1 | 1,2 | 1,4 | 1,6 | 1,8 | 2 | 2,2 | 2,4 |
| | Portata - Capacity | | | | | | | | | | |
| | Q (l/s) | | | | | | | | | | |
| GM - GT 32/2/110 C.149 | | | 3,5 | 2,5 | 1,8 | 1,4 | 0,8 | 0,25 | | | |

Dati tecnici / Specifications

| | Mandata Delivery | kW | | r.p.m | Poles | Hz | Ampere | | |
|------------------------|---------------------|-----|-----|-------|-------|----|--------|----|----------|
| | | P1 | P2 | 1/min | | | 1~ | | 400 V 3~ |
| | | | | | | | 230 V | uf | |
| GM - GT 32/2/110 C.149 | G 1 1/4 " | 1,1 | 0,9 | 2850 | 2 | 50 | 6,5 | 30 | 2,5 |

Dimensioni di ingombro dell'imballo
Overall dimensions of packing

| TIPO-TYPE | X | Y | Z | Kg |
|------------------------|-----|-----|-----|----|
| GM - GT 32/2/110 C.149 | 260 | 550 | 220 | 25 |

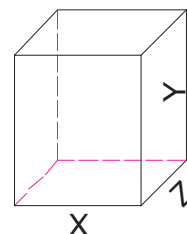

GM-GT 32/2/110 C.149

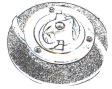



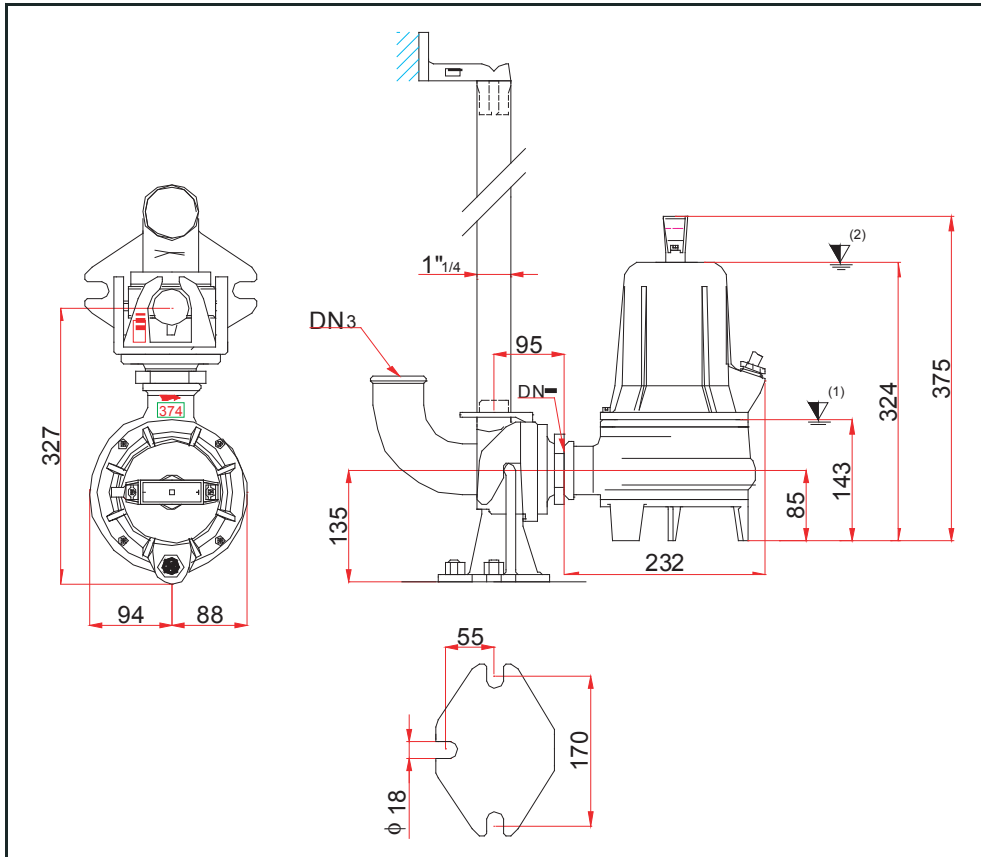

INSTALLAZIONE FISSA
STATIONARY INSTALLATION



(1) Punto inferiore d'arresto nel caso di funzionamento automatico
Lowest shut-off point for automatic operation

(2) Sommergenza minima nel caso di funzionamento continuo
Minimum covering for continuous operation

CARATTERISTICHE TECNICHE - TECHNICAL FEATURES

| TIPO - TYPE | DN2 Mandata filettata | DN3 | CAVO - CABLE H07 - RNF | MT |  |  |  | OPTIONAL |
|-------------------|--------------------------|-----------|--|-----------|---|---|---|---|
| GM 32/2/110 C.149 | G 1 1/4 " | 2" | (1) 4x1,5 φ 11,5 Pannello di controllo Control panel Tableaut automatique | 10 | Superiore Upper | Inferiore Lower | Superiore Upper |  |
| GT 32/2/110 C.149 | | | 1) 4x1,5 φ 11,5 con terminali liberi with free cable terminals avec bornes libres | | 6302 2Z | 6202 2Z | Tipo: B1 | |

GM-GT 32/2/125 C.150-155-160

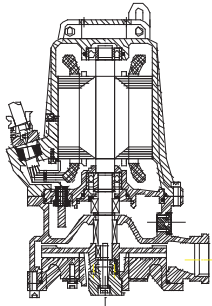

GIRANTE CON TRITURATORE
IMPELLER FOR GRINDER



PASSAGGIO LIBERO 6mm
FREE PASSAGE 6mm

ALBERO MOTORE AISI 420
MOTOR SHAFT AISI 420

Curve secondo ISO 9906. Livello 2
Curves as per ISO 9906. Grade 2

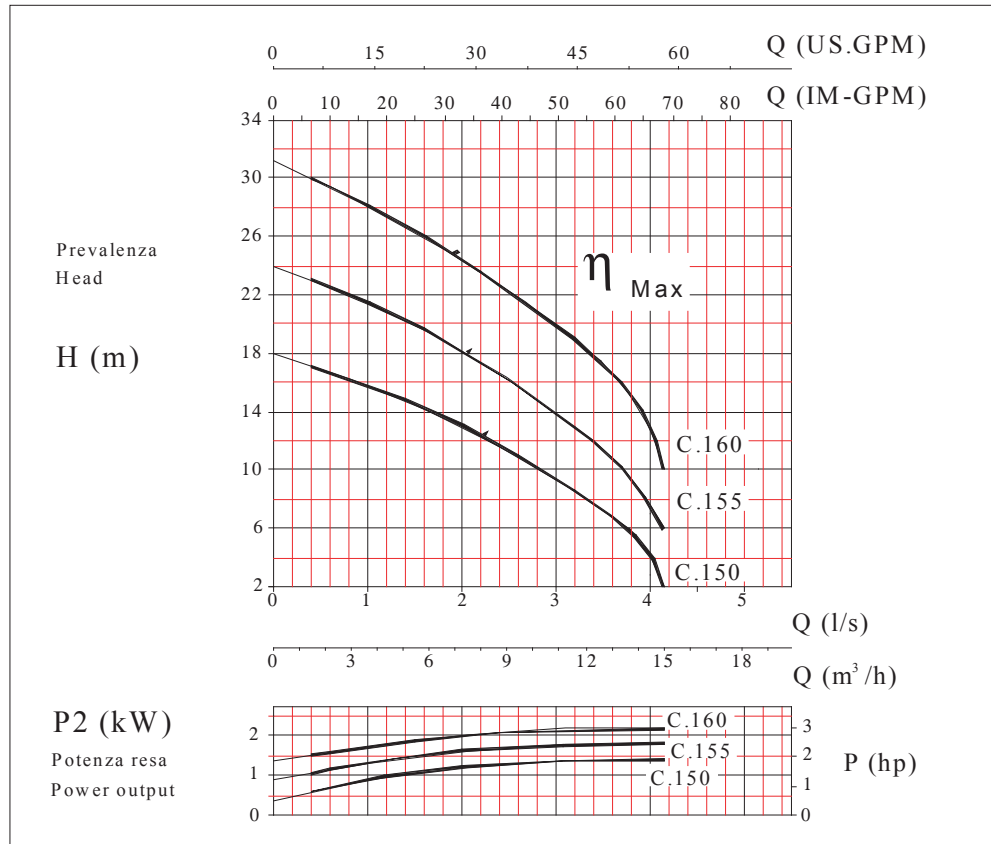

| Elettropompa Tipo Electric pump Type | Prevalenza - Head | | | | | | | | | | |
|---|--------------------|-----|-----|-----|-----|-----|-----|-----|-----|-----|-----|
| | Hm bar | | | | | | | | | | |
| | 4 | 6 | 10 | 12 | 14 | 16 | 18 | 20 | 24 | 30 | 32 |
| | 0,4 | 0,6 | 1 | 1,2 | 1,4 | 1,6 | 1,8 | 2 | 2,4 | 3 | 3,2 |
| | Portata - Capacity | | | | | | | | | | |
| | Q (l/s) | | | | | | | | | | |
| GM-GT 32/2/125 C.150 | 4 | 3,8 | 2,8 | 2,4 | 1,7 | 0,8 | | | | | |
| GM-GT 32/2/125 C.155 | | 4 | 3,8 | 3,4 | 3 | 2,6 | 2 | 1,2 | | | |
| GM-GT 32/2/125 C.160 | | | 4,1 | 4 | 3,9 | 3,6 | 3,4 | 3,7 | 2,2 | 0,5 | |

Dati tecnici Specifications

| | Mandata Delivery | kW | | r.p.m | Poles | Hz | Ampere | | |
|----------------------|---------------------|------|-----|-------|-------|----|--------|----|----------|
| | | P1 | P2 | 1/min | | | 1- | | 400 V 3- |
| | | | | | | | 230 V | uf | |
| GM-GT 32/2/125 C.150 | G 1 1/4 | 1,05 | 1,4 | 2850 | 2 | 50 | 15,0 | 40 | 5,5 |
| GM-GT 32/2/125 C.155 | | 2,4 | 1,8 | 2850 | 2 | 50 | 15,3 | 50 | 4,0 |
| GM-GT 32/2/125 C.160 | | 3,1 | 2,3 | 2850 | 2 | 50 | 16,5 | 50 | 5,5 |

**Dimensioni di ingombro dell'imballo
Overall dimensions of packing**

| TIPO-TYPE | X | Y | Z | Kg |
|----------------------|-----|-----|-----|------|
| GM-GT 32/2/125 C.150 | 295 | 460 | 310 | 38 |
| GM-GT 32/2/125 C.155 | 295 | 460 | 310 | 37,5 |
| GM-GT 32/2/125 C.160 | 295 | 460 | 310 | 40 |

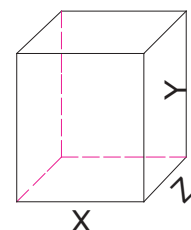

GM-GT 32/2/125 C.150-155-160



INSTALLAZIONE FISSA
STATIONARY INSTALLATION

INSTALLAZIONE MOBILE
MOBILE INSTALLATION

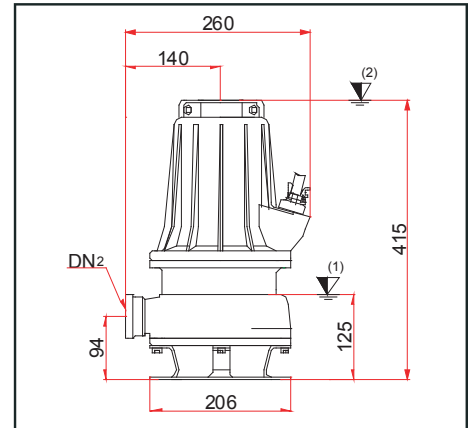
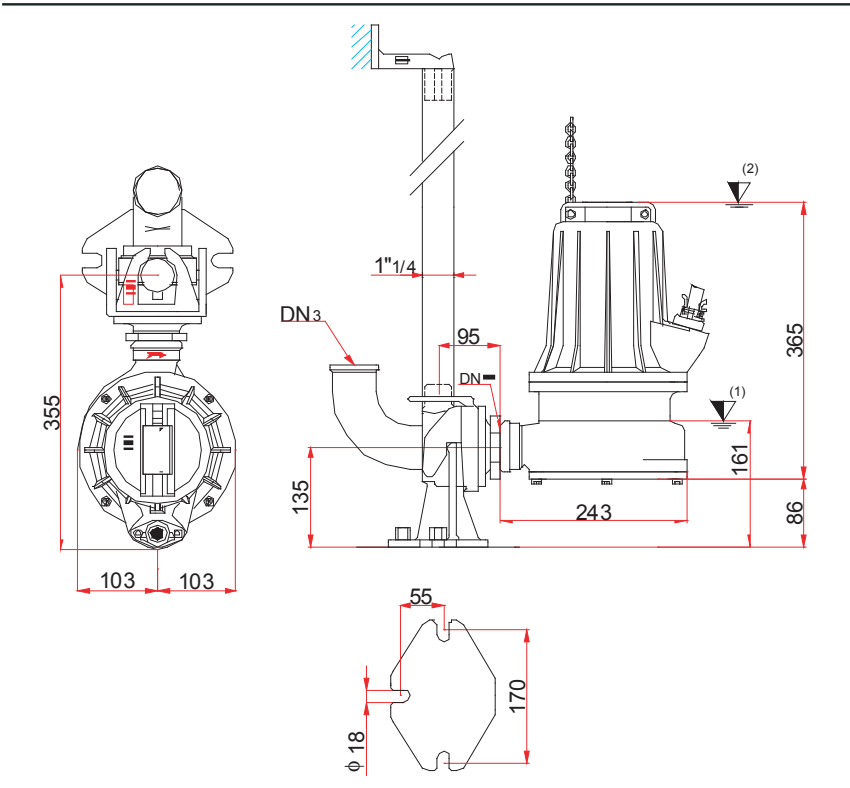

CARATTERISTICHE TECNICHE - TECHNICAL FEATURES

| TIPO - TYPE | DN2 Mandata filettata | DN3 | CAVO - CABLE H07 - RNF | MT | OPTIONAL | |
|---|--------------------------|-----|---|----|----------|----------|
| GM 32/2/125 C.150 GM 32/2/125 C.155 GM 32/2/125 C.160 | G 1" ° | 2" | (1) 7x1,5 φ 15 Pannello di controllo Control panel | 10 | | |
| GT 32/2/125 C.150 GT 32/2/125 C.155 GT 32/2/125 C.160 | | | (1) 7x1,5 φ 15 con terminali liberi with free cable terminals | | Tipo: B1 | Tipo: P1 |

CARATTERISTICHE TECNICHE - TECHNICAL FEATURES

| TIPO - TYPE | Sonde termiche Thermal probes | yes | | | | |
|-------------|--|-----|---|----------------|--------------------|--------------------|
| | GM-GT 32/2/125 C.150 GM-GT 32/2/125 C.155 GM-GT 32/2/125 C.160 | | Sonda di conduttività Conductivity probe | yes | Superiore Upper | Inferiore Lower |
| | | | AR 20 | MG 1S20/20-G26 | 6204 2Z | 3204 2Z |

NOTE - NOTES :

Punto inferiore d'arresto nel caso di funzionamento automatico
Lowest shut-off point for automatic operation

Sommergenza minima nel caso di funzionamento continuo
Minimum covering for continuous operation

GT 65/2/152 C. 165-170

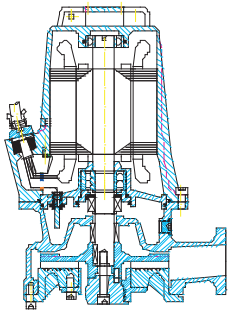

GIRANTE CON TRITURATORE
IMPELLER FOR GRINDER



| | |
|------------------|-----|
| PASSAGGIO LIBERO | 8mm |
| FREE PASSAGE | 8mm |

| | |
|---------------|----------|
| ALBERO MOTORE | AISI 420 |
| MOTOR SHAFT | AISI 420 |

Curve secondo ISO 9906. Livello 2
Curves as per ISO 9906. Grade 2

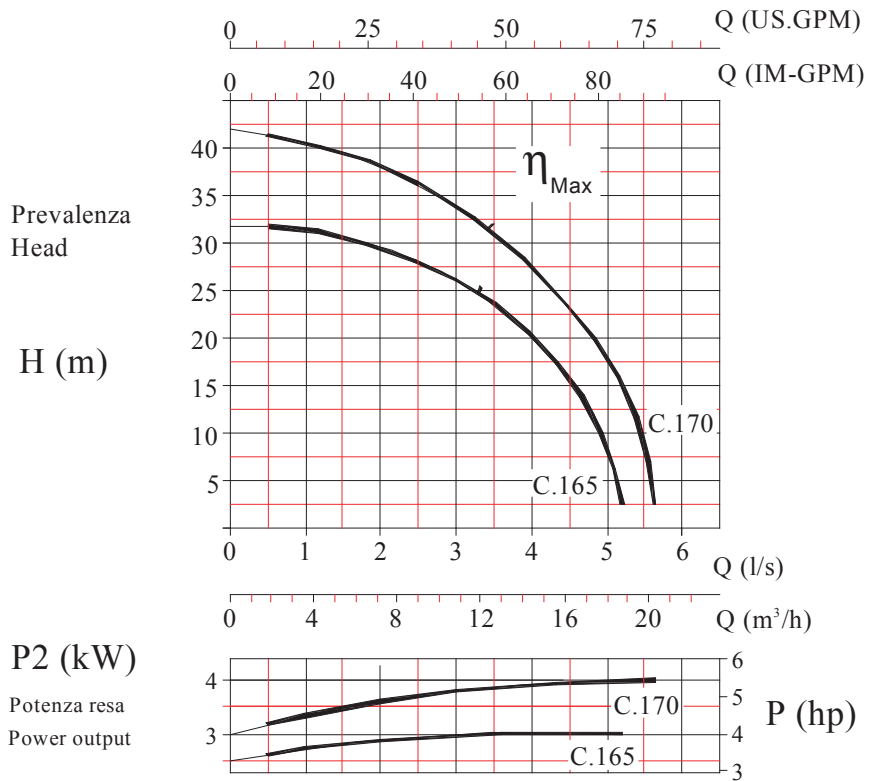

| Elettropompa Tipo Electric pump Type | Prevalenza - Head | | | | | | | | | | |
|---|--------------------|-----|-----|-----|-----|-----|-----|------|------|-----|----|
| | Hm bar | | | | | | | | | | |
| | 2,5 | 5 | 10 | 15 | 20 | 25 | 30 | 35 | 40 | 45 | 50 |
| | 0,25 | 0,5 | 1 | 1,5 | 2 | 2,5 | 3 | 3,5 | 4 | 4,5 | 5 |
| | Portata - Capacity | | | | | | | | | | |
| | Q (l/s) | | | | | | | | | | |
| GT 65/2/152 C.165 | 5,3 | 5,2 | 5 | 4,6 | 4 | 3,3 | 1,8 | | | | |
| GT 65/2/152 C.170 | | 5,6 | 5,5 | 5,2 | 4,8 | 4,3 | 3,6 | 2,75 | 1,25 | | |

Dati tecnici / Specifications

| | Mandata Delivery | kW | | r.p.m | Poles | Ampere | Hz | Cos φ |
|-------------------|---------------------|-----|----|-------|-------|------------|----|-------|
| | | P1 | P2 | 1/min | | Trifase 3~ | | |
| | | | | | | 400V | | |
| GT 65/2/152 C.165 | DN2 65 | 4,8 | 3 | 2850 | 2 | 7,9 | 50 | 0,89 |
| GT 65/2/152 C.170 | | 6 | 4 | 2850 | 2 | 9,4 | 50 | 0,92 |

Dimensioni di ingombro dell'imballo
Overall dimensions of packing

| TIPO-TYPE | X | Y | Z | Kg |
|-------------------|-----|-----|-----|----|
| GT 65/2/152 C.165 | 340 | 550 | 420 | 61 |
| GT 65/2/152 C.170 | 340 | 550 | 420 | 62 |

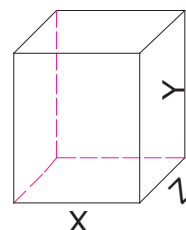

Dimensioni - Dimensions
GT 65/2/152 C. 165-170

 INSTALLAZIONE FISSA
 STATIONARY INSTALLATION

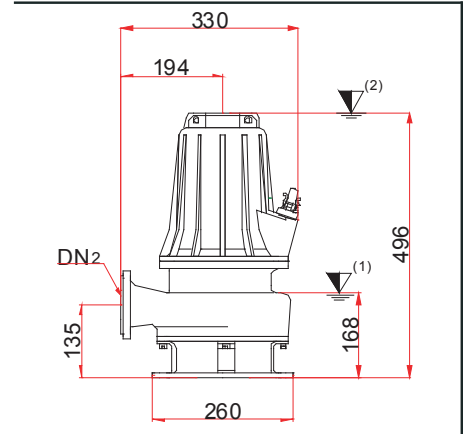
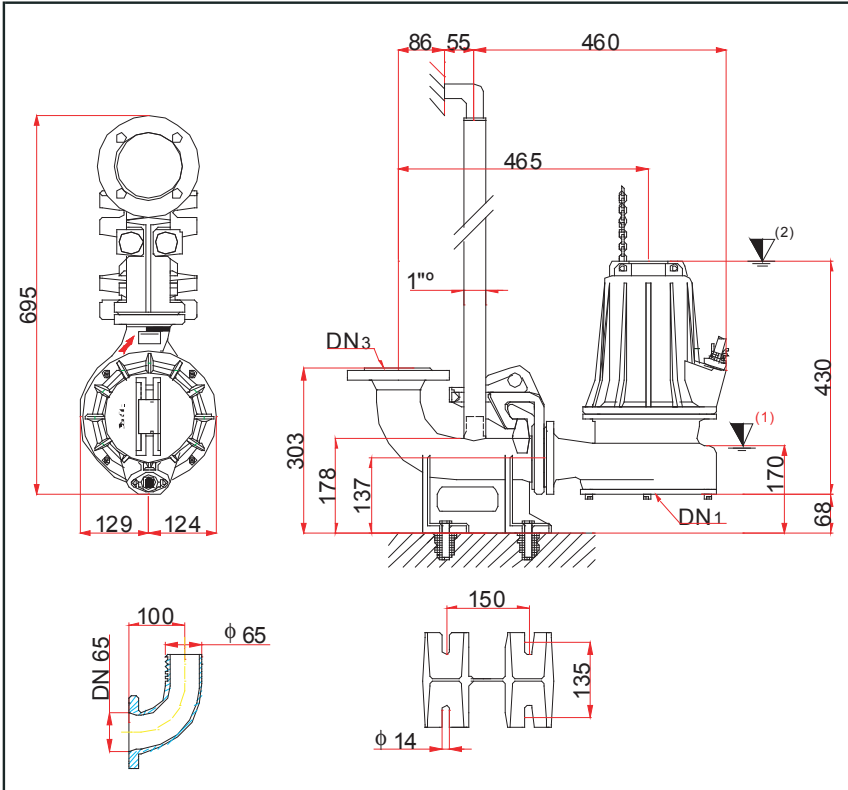
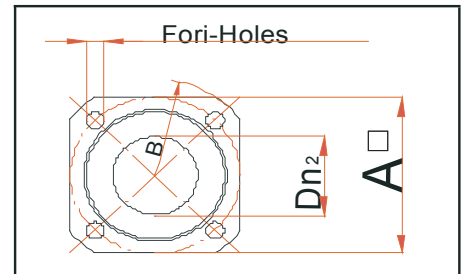
 INSTALLAZIONE MOBILE
 MOBILE INSTALLATION

 Dimensioni flange UNI
 UNI flange dimensions

DIMENSIONI FLANGE UNI - UNI FLANGE DIMENSIONS

| TIPO - TYPE | DN 1 | DN 2/3 | A | B | Fori - Holes | | OPTIONAL | | | |
|--|------|--------|-----|-----|--------------|------|----------|----------|-------|--|
| | | | | | n° | ϕ mm | | | | |
| GT 65/2/152 C.165 GT 65/2/152 C.170 | 65 | 65 | 130 | 160 | 4 | 14 | P2-DN 65 | B4-DN 65 | DN 65 | |

CARATTERISTICHE TECNICHE - TECHNICAL FEATURES

| TIPO - TYPE | CAVO - CABLE H07 - RNF | MT | Sonde termiche | si | | | | |
|--|--------------------------------|----|-----------------------|-----|-----------|-------------|-----------|-----------|
| | | | Thermal probes | yes | | | | |
| GT 65/2/152 C. 165 GT 65/2/152 C. 170 | (1) 7x1,5 ϕ 15 AVV. DIRETTO | 10 | Sonda di conduttività | si | Superiore | Inferiore | Superiore | Inferiore |
| | | | Conductivity probe | yes | AR25 | MG1/25 - G6 | 6205 2Z | 3205 2Z |

NOTE - NOTES :

 Punto inferiore d'arresto nel caso di funzionamento automatico
 Lowest shut-off point for automatic operation

 Sommergenza minima nel caso di funzionamento continuo
 Minimum covering for continuous operation

GT 65/2/152 C. 175-180

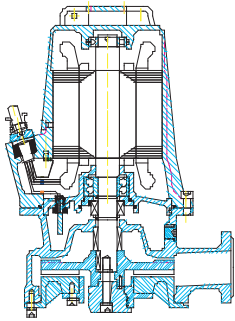

GIRANTE CON TRITURATORE
IMPELLER FOR GRINDER



| | |
|------------------|------|
| PASSAGGIO LIBERO | 10mm |
| FREE PASSAGE | 10mm |

| | |
|---------------|----------|
| ALBERO MOTORE | AISI 420 |
| MOTOR SHAFT | AISI 420 |

Curve secondo ISO 9906. Livello 2
Curves as per ISO 9906. Grade 2

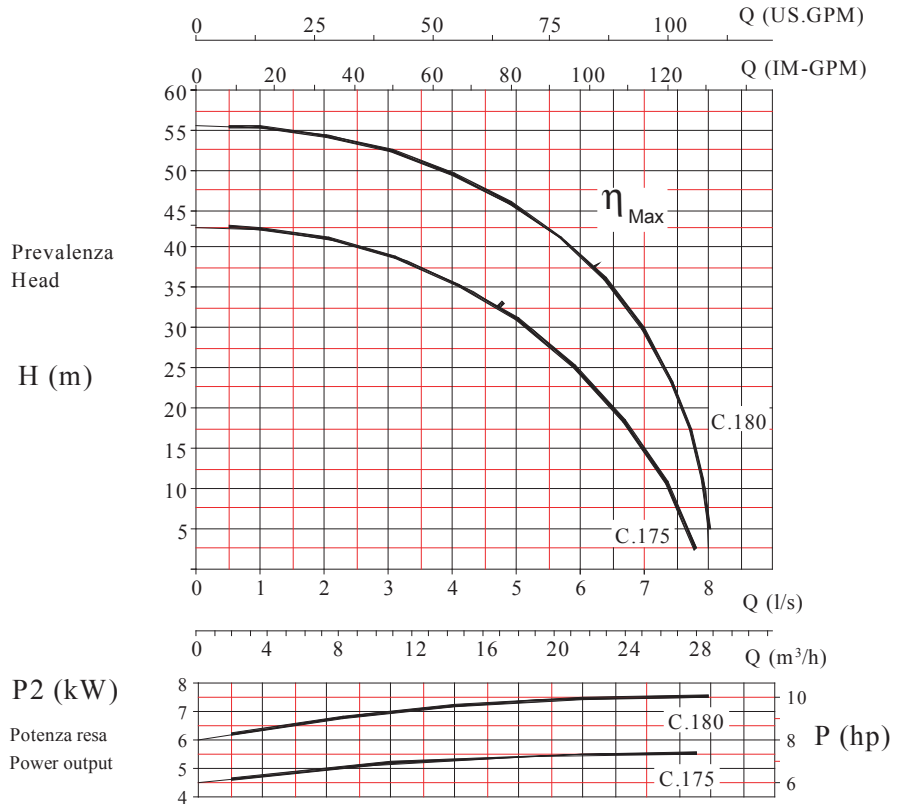

| Elettropompa Tipo Electric pump Type | Prevalenza - Head | | | | | | | | | | | |
|---|--------------------|-----|------|-----|-----|-----|-----|-----|----|----|-----|--|
| | Hm bar | | | | | | | | | | | |
| | 5 | 10 | 15 | 20 | 25 | 30 | 35 | 40 | 45 | 50 | 55 | |
| | Portata - Capacity | | | | | | | | | | | |
| | Q (l/s) | | | | | | | | | | | |
| GT 65/2/173 C.175 | 7,8 | 7,4 | 7 | 6,5 | 5,9 | 5,3 | 4 | 2,5 | | | | |
| GT 65/2/173 C.180 | 8 | 7,9 | 7,75 | 7,6 | 7,4 | 7 | 6,5 | 5,8 | 5 | 4 | 1,5 | |

Dati tecnici / Specifications

| | Mandata Delivery | kW | | r.p.m | Poles | Ampere | Hz | Cos φ | |
|-------------------|---------------------|-----|-----|-------|-------|------------|----|-------|--|
| | | P1 | P2 | 1/min | | Trifase 3~ | | | |
| | | | | | | 400V | | | |
| GT 65/2/173 C.175 | DN2 65 | 8,2 | 5,5 | 2850 | 2 | 13,5 | 50 | 0,83 | |
| GT 65/2/173 C.180 | | 11 | 7,5 | 2850 | 2 | 17,5 | 50 | 0,87 | |

Dimensioni di ingombro dell'imballo
Overall dimensions of packing

| TIPO-TYPE | X | Y | Z | Kg |
|-------------------|-----|-----|-----|----|
| GT 65/2/173 C.175 | 340 | 550 | 420 | 85 |
| GT 65/2/173 C.180 | 340 | 550 | 420 | 86 |

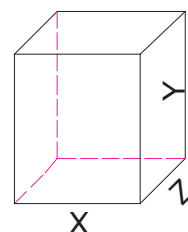

GT 65/2/173 C. 175-180



INSTALLAZIONE FISSA
STATIONARY INSTALLATION

INSTALLAZIONE MOBILE
MOBILE INSTALLATION

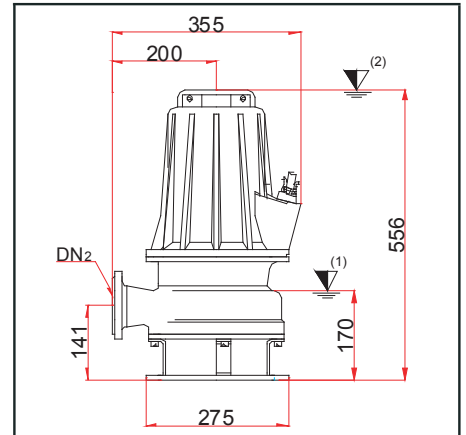
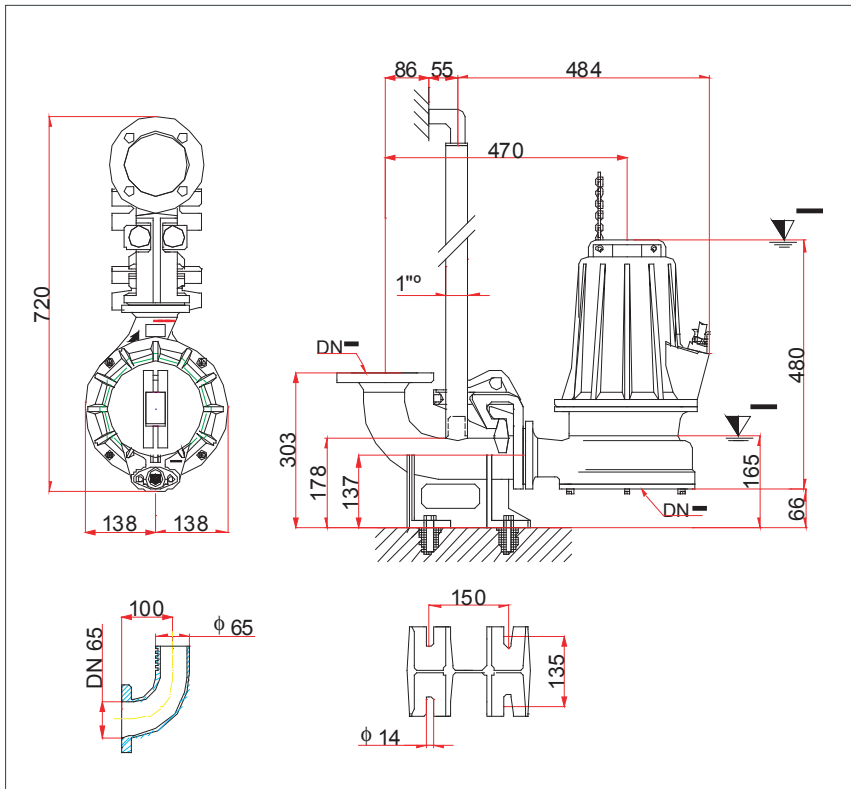

Dimensioni flange UNI
UNI flange dimensions

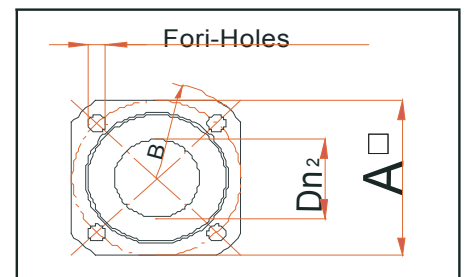

DIMENSIONI FLANGE UNI - UNI FLANGE DIMENSIONS

| TIPO - TYPE | DN 1 | DN 2/3 | A | B | Fori - Holes - Trous | | OPTIONAL | | | |
|--|------|--------|-----|-----|----------------------|------|----------|----------|-------|--|
| | | | | | n° | φ mm | | | | |
| GT 65/2/173 C.175 GT 65/2/173 C.180 | 65 | 65 | 130 | 160 | 4 | 14 | P3-DN 65 | B4-DN 65 | DN 65 | |

CARATTERISTICHE TECNICHE - TECHNICAL FEATURES

| TIPO - TYPE | CAVO - CABLE H07 - RNF | MT | Sonde termiche | si | | | | |
|--|---------------------------|----|-----------------------|-----|--------------------|--------------------|--------------------|--------------------|
| | | | Thermal probes | yes | Superiore Upper | Inferiore Lower | Superiore Upper | Inferiore Lower |
| GT 65/2/173 C.175 GT 65/2/173 C.180 | (1) 10x1,5 φ 20 Y-Δ | 10 | Sonda di conduttività | si | AR 30 | MG1/30/G6 | 6206 2Z 32-2-25 | 3206 2Z |
| | | | Conductivity probe | yes | | | | |

NOTE - NOTES :



Punto inferiore d'arresto nel caso di funzionamento automatico
Lowest shut-off point for automatic operation



Sommergenza minima nel caso di funzionamento continuo
Minimum covering for continuous operation

AM-AT 40/2/110 C.218-219

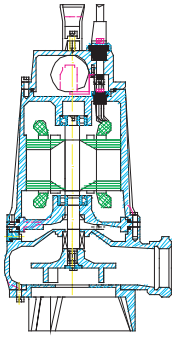

GIRANTE BICANALE
DOUBLE CHANNEL IMPELLER

PASSAGGIO LIBERO
FREE PASSAGE

| | |
|--------|-------|
| C. 218 | 14 mm |
| C. 219 | 19 mm |

| | |
|---------------|----------|
| ALBERO MOTORE | AISI 420 |
| MOTOR SHAFT | AISI 420 |

Curve secondo ISO 9906. Livello 2
Curves as per ISO 9906. Grade 2

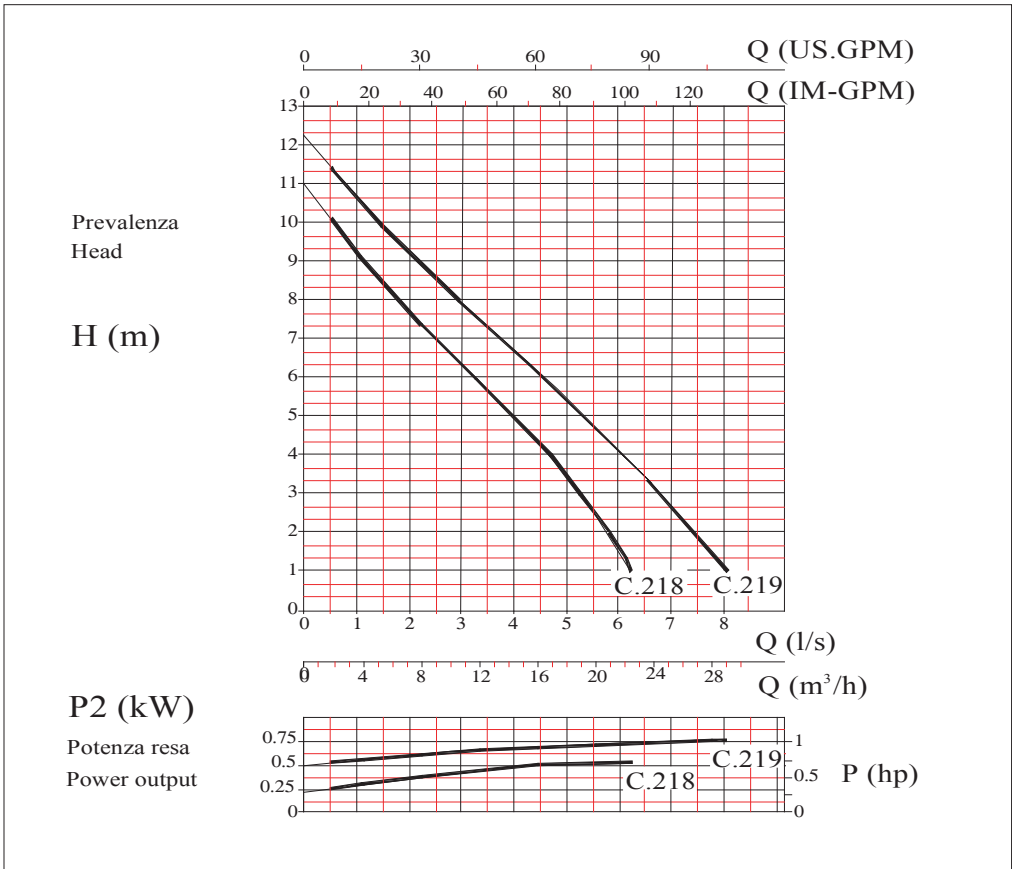

| Elettropompa Tipo Electric pump Type | Prevalenza - Head | | | | | | | | | | |
|---|-------------------|-----|-----|-----|-----|-----|-----|-----|-----|-----|-----|
| | Hm bar | | | | | | | | | | |
| | 1 | 2 | 3 | 4 | 5 | 6 | 7 | 8 | 9 | 10 | 11 |
| | 0,1 | 0,2 | 0,3 | 0,4 | 0,5 | 0,6 | 0,7 | 0,8 | 0,9 | 1 | 1,1 |
| Portata - Capacity | | | | | | | | | | | |
| Q (l/s) | | | | | | | | | | | |
| AM-AT 40/2/110 C.218 | 6,2 | 5,9 | 5,3 | 4,6 | 4 | 3,2 | 2,5 | 1,9 | 1,1 | 0,6 | |
| AM-AT 40/2/110 C.219 | 8 | 7,5 | 6,9 | 6 | 5,3 | 4,5 | 3,7 | 3 | 2,2 | 1,4 | 0,7 |

Dati tecnici / Specifications

| | Mandata Delivery | kW | | r.p.m | Poles | Hz | Ampere | | |
|----------------------|---------------------|-----|------|-------|-------|----|--------|----|----------|
| | | P1 | P2 | 1/min | | | 1~ | | 400 V 3~ |
| | | | | | | | 230 V | uf | |
| AM-AT 40/2/110 C.218 | G 1 1/2 " | 0,7 | 0,56 | 2850 | 2 | 50 | 4,1 | 16 | 1,4 |
| AM-AT 40/2/110 C.219 | | 0,9 | 0,75 | 2850 | 2 | 50 | 5,1 | 20 | 1,9 |

AM = 1~ 230 VOLT - 50 Hz AT = 3~ 400 VOLT - 50 Hz

Dimensioni di ingombro dell'imballo
Overall dimensions of packing

| TIPO-TYPE | X | Y | Z | Kg |
|----------------------|-----|-----|-----|----|
| AM-AT 40/2/110 C.218 | 250 | 440 | 210 | 19 |
| AM-AT 40/2/110 C.219 | 250 | 440 | 210 | 19 |

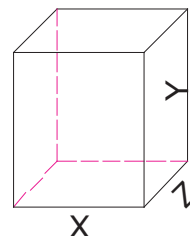

AM-AT 40/2/110 C.218-219



INSTALLAZIONE FISSA
STATIONARY INSTALLATION

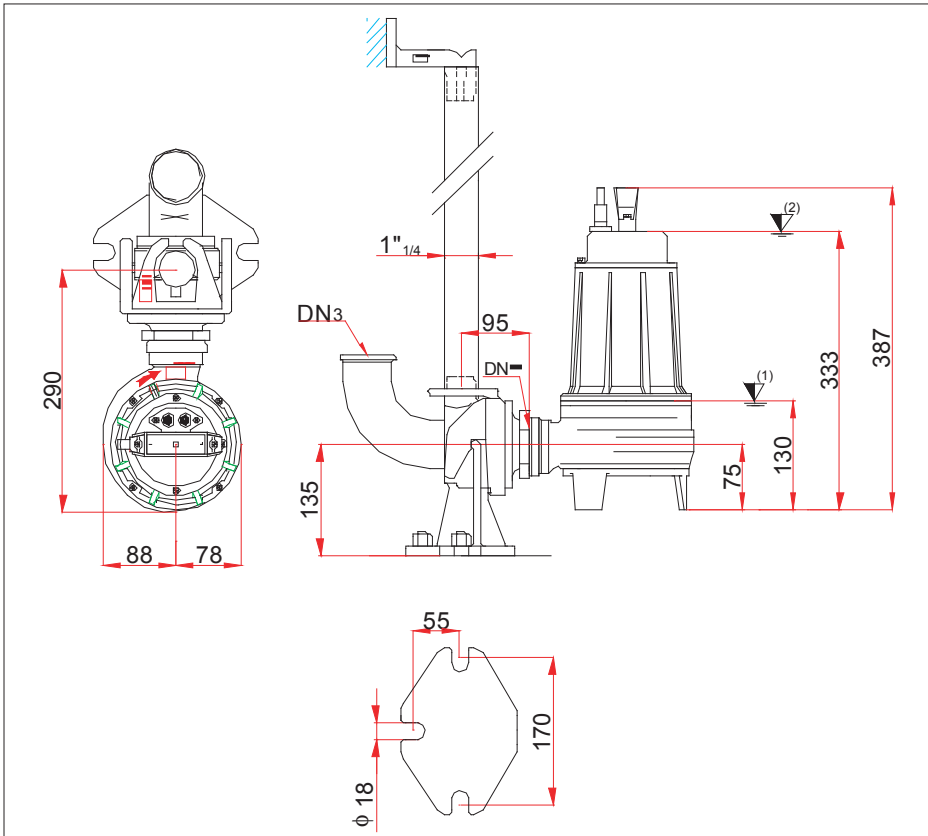

(1) Punto inferiore d'arresto nel caso di funzionamento automatico
Lowest shut-off point for automatic operation

(2) Sommergenza minima nel caso di funzionamento continuo
Minimum covering for continuous operation

CARATTERISTICHE TECNICHE - TECHNICAL FEATURES

| TIPO - TYPE | DN2 | DN3 | CAVO - CABLE H07 - RNF | MT | | | | | OPTIONAL | |
|--|-------------------|-----|--|----|--------------------|--------------------|--------------------|--------------------|----------|--|
| | Mandata filettata | | | | | | | | | |
| AM 40/2/110 C.218 AM 40/2/110 C.219 | G 1 1/2" | 2" | (1) 3x1 φ 9 Schuko-plug | 10 | Superiore Upper | Inferiore Lower | Superiore Upper | Inferiore Lower | | |
| AT 40/2/110 C.218 AT 40/2/110 C.219 | | | (1) 4x1 φ 10 con terminali liberi with free cable terminal | | SC 15-26-6 | MG 1S2/14/G6 | 6201 2Z | 6202 2Z | | |

AM-AT 50/2/110 C.225-226

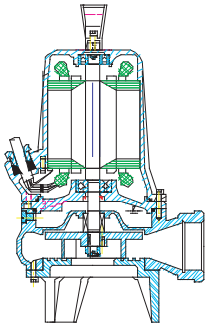

GIRANTE BICANALE
DOUBLE CHANNEL IMPELLER



PASSAGGIO LIBERO
FREE PASSAGE

| | |
|--------|-------|
| C. 225 | 19 mm |
| C. 226 | 24 mm |

| | |
|---------------|----------|
| ALBERO MOTORE | AISI 420 |
| MOTOR SHAFT | AISI 420 |

Curve secondo ISO 9906. Livello 2
Curves as per ISO 9906. Grade 2

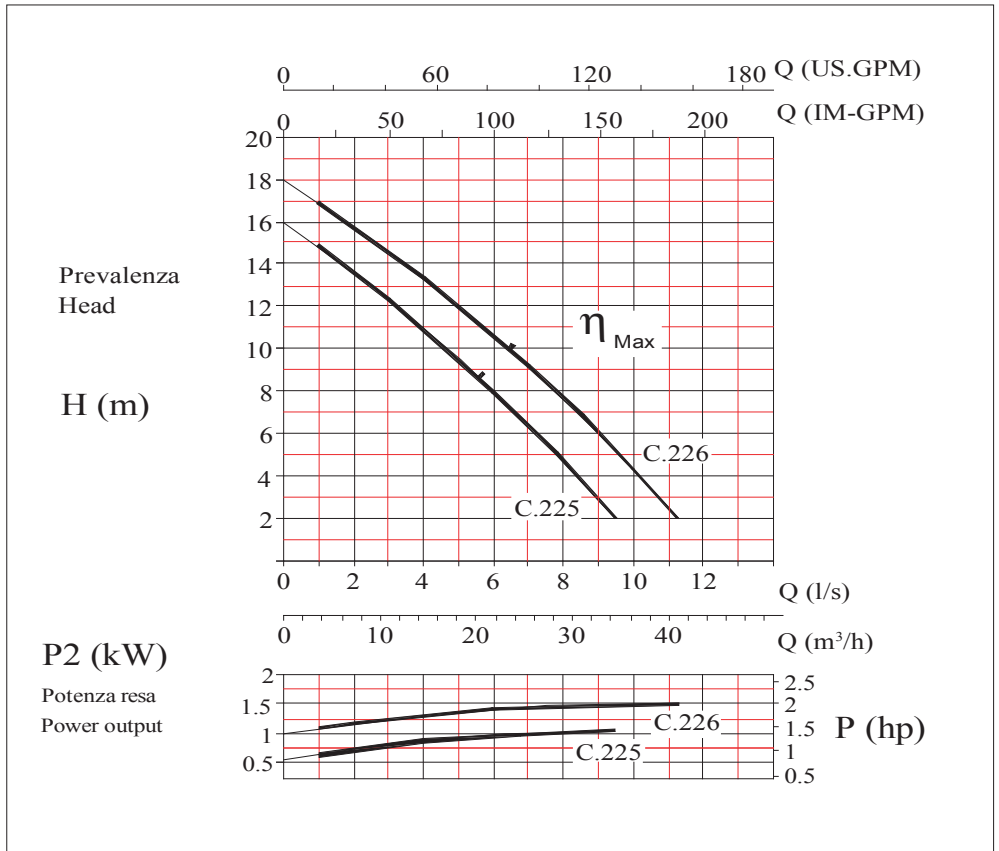

| Elettropompa Tipo Electric pump Type | Prevalenza - Head | | | | | | | | | | |
|---|--------------------|------|-----|-----|-----|-----|-----|-----|-----|-----|----|
| | Hm bar | | | | | | | | | | |
| | 1 | 2 | 4 | 6 | 8 | 10 | 12 | 14 | 16 | 18 | 20 |
| | 0,1 | 0,2 | 0,4 | 0,6 | 0,8 | 1 | 1,2 | 1,4 | 1,6 | 1,8 | 2 |
| | Portata - Capacity | | | | | | | | | | |
| | Q (l/s) | | | | | | | | | | |
| AM-AT 50/2/110 C.225 | | 9,5 | 8,4 | 7,1 | 6 | 4,6 | 3,2 | 1,8 | | | |
| AM-AT 50/2/110 C.226 | | 11,2 | 10 | 9 | 7,8 | 6,5 | 5 | 3,4 | 2 | | |

Dati tecnici / Specifications

| | Mandata Delivery | kW | | r.p.m | Poles | Hz | Ampere | | |
|----------------------|---------------------|-----|-----|-------|-------|----|--------|------|----------|
| | | P1 | P2 | 1/min | | | 1~ | | 400 V 3~ |
| | | | | | | | 230 V | uf | |
| AM-AT 50/2/110 C.225 | G 2" | 1,4 | 1,1 | 2850 | 2 | 50 | 8,4 | 31,5 | 2,7 |
| AM-AT 50/2/110 C.226 | | 1,9 | 1,5 | 2850 | 2 | 50 | 11,4 | 40 | 3,4 |

AM = 1~ 230 VOLT - 50 Hz AT = 3~ 400 VOLT - 50 Hz

Dimensioni di ingombro dell'imballo
Overall dimensions of packing

| TIPO-TYPE | X | Y | Z | Kg |
|----------------------|-----|-----|-----|----|
| AM-AT 50/2/110 C.225 | 250 | 440 | 210 | 24 |
| AM-AT 50/2/110 C.226 | 250 | 440 | 210 | 24 |

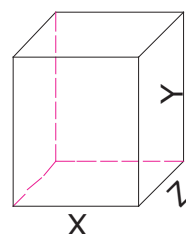

AM-AT 50/2/110 C.225-226



INSTALLAZIONE FISSA
STATIONARY INSTALLATION

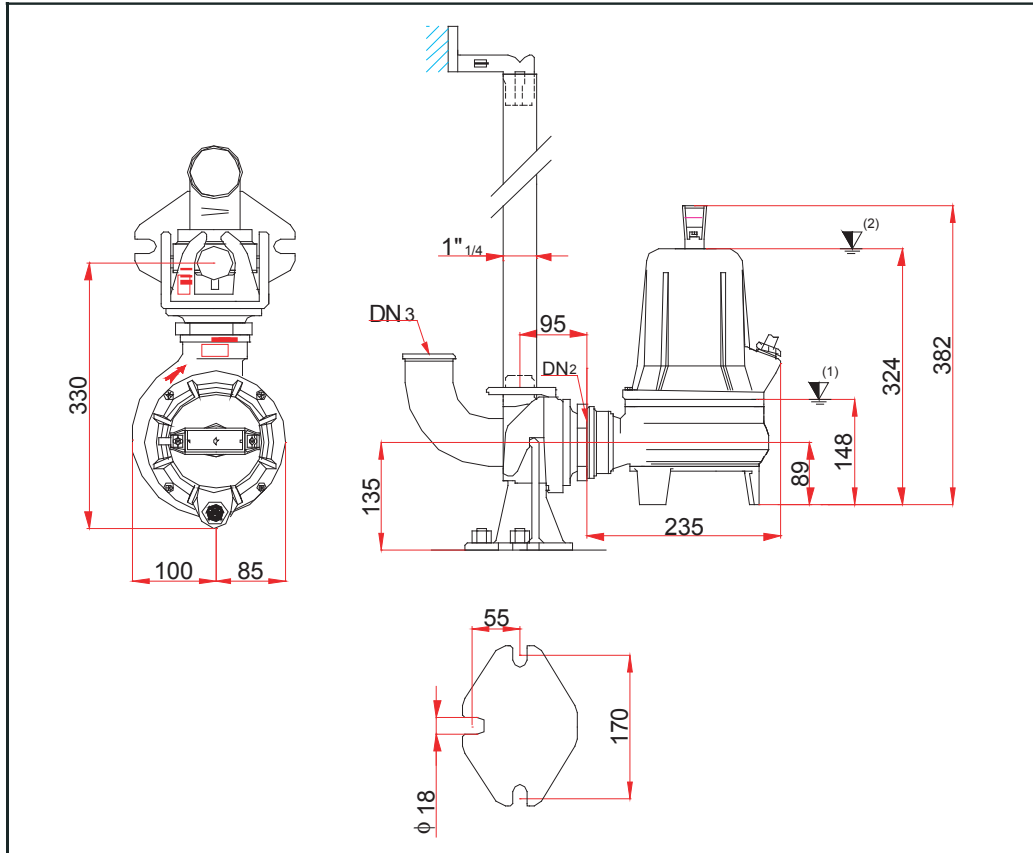

(1) Punto inferiore d'arresto nel caso di funzionamento automatico
Lowest shut-off point for automatic operation

(2) Sommergenza minima nel caso di funzionamento continuo
Minimum covering for continuous operation

CARATTERISTICHE TECNICHE - TECHNICAL FEATURES

| TIPO - TYPE | DN2 Mandata filettata | DN3 | CAVO - CABLE H07 - RNF | MT | | | | | OPTIONAL | |
|--|--------------------------|-----|---|----|--------------------|--------------------|--------------------|--------------------|----------|--|
| | | | | | | | | | | |
| AM 50/2/110 C.225 AM 50/2/110 C.226 | G 2" | 2" | (1) 4x1,5 ϕ 11,5 con scatola porta condensatore | 10 | Superiore Upper | Inferiore Lower | Superiore Upper | Inferiore Lower | | |
| AT 50/2/110 C.225 AT 50/2/110 C.226 | | | (1) 4x1,5 ϕ 11,5 con terminali liberi with free cable terminal | | SC 15-26-6 | MG1S2/14/G6 | 6202 2Z | 6302 2Z | | |

AM-AT 65/2/125 C.236-237

On request

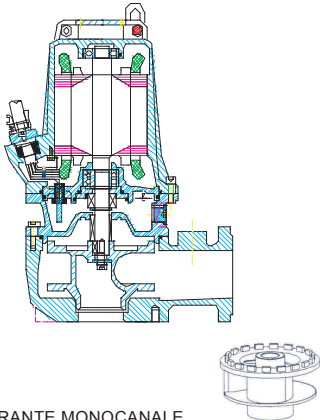

GIRANTE MONOCANALE
IMPELLER SINGLECHANNEL

| | |
|------------------|------|
| PASSAGGIO LIBERO | 40mm |
| FREE PASSAGE | 40mm |

| | |
|---------------|----------|
| ALBERO MOTORE | AISI 420 |
| MOTOR SHAFT | AISI 420 |

Curve secondo ISO 9906. Livello 2
Curves as per ISO 9906. Grade 2

Prevalenza
Head

H (m)

P2 (Kw)

Potenza resa
Power output

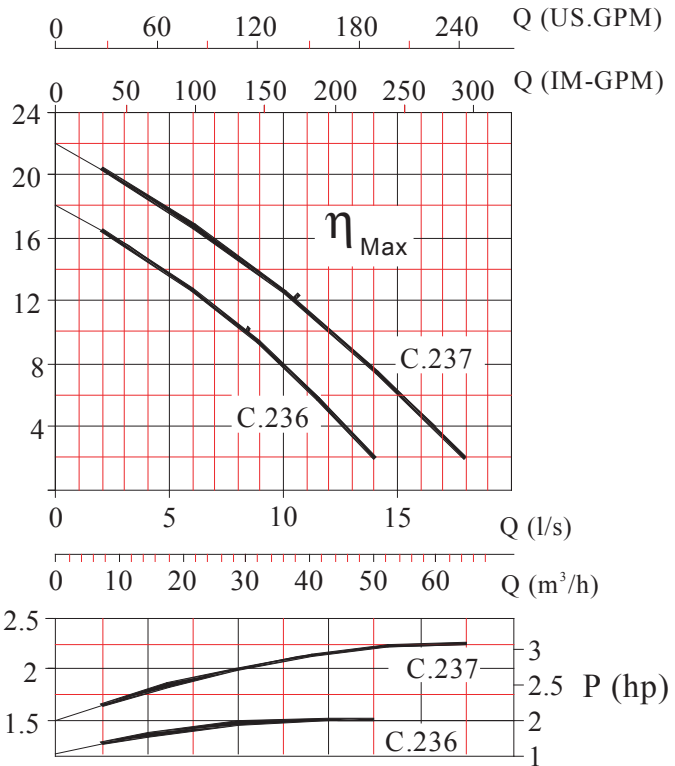

| Elettropompa Tipo Electric pump Type | Prevalenza - Head | | | | | | | | | | |
|---|--------------------|------|------|------|-----|------|-----|-----|-----|----|-----|
| | Hm bar | | | | | | | | | | |
| | 2 | 4 | 6 | 8 | 10 | 12 | 14 | 16 | 18 | 20 | 22 |
| | 0,2 | 0,4 | 0,6 | 0,8 | 1 | 1,2 | 1,4 | 1,6 | 1,8 | 2 | 2,2 |
| | Portata - Capacity | | | | | | | | | | |
| | Q (l/s) | | | | | | | | | | |
| | | | | | | | | | | | |
| AM-AT 65/2/125 C. 236 | 14 | 12,6 | 11,2 | 10 | 8,5 | 6,5 | 4,8 | 2,5 | | | |
| AT 65/2/125 C. 237 | 18 | 16,5 | 15 | 13,8 | 12 | 10,5 | 8,5 | 7 | 5 | 2 | |

Dati tecnici / Specifications

| | Mandata Delivery | kW | | r.p.m | Poles | Hz | Ampere | | | Cos φ |
|-----------------------|---------------------|-----|-----|-------|-------|----|-------------|----|----------|-------|
| | | P1 | P2 | 1/min | | | 1~ 230 V | uf | 400 V 3~ | |
| | | | | | | | | | | |
| AM-AT 65/2/125 C. 236 | DN2 65 | 2,4 | 1,5 | 2850 | 2 | 50 | 11 | 40 | 3,6 | 0,91 |
| AT 65/2/125 C. 237 | | 3,1 | 2,2 | 2850 | 2 | 50 | | | 5,1 | 0,87 |

Dimensioni di ingombro dell'imballo
Overall dimensions of packing

| TIPO-TYPE | X | Y | Z | Kg |
|-----------------------|-----|-----|-----|------|
| AM-AT 65/2/125 C. 236 | 295 | 460 | 310 | 41 |
| AT 65/2/125 C. 237 | 295 | 460 | 310 | 42,5 |

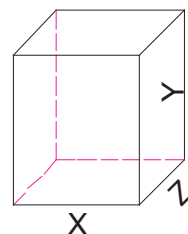

AM-AT 65/2/125 C. 236-237

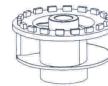

INSTALLAZIONE FISSA
STATIONARY INSTALLATION

INSTALLAZIONE MOBILE
MOBILE INSTALLATION

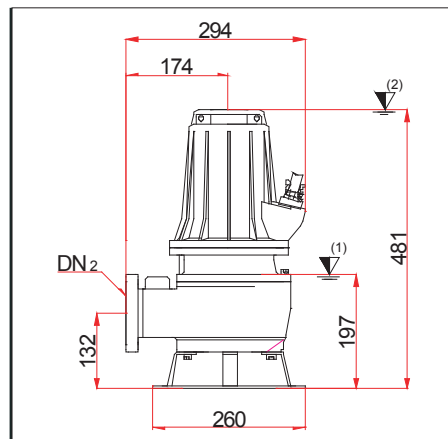
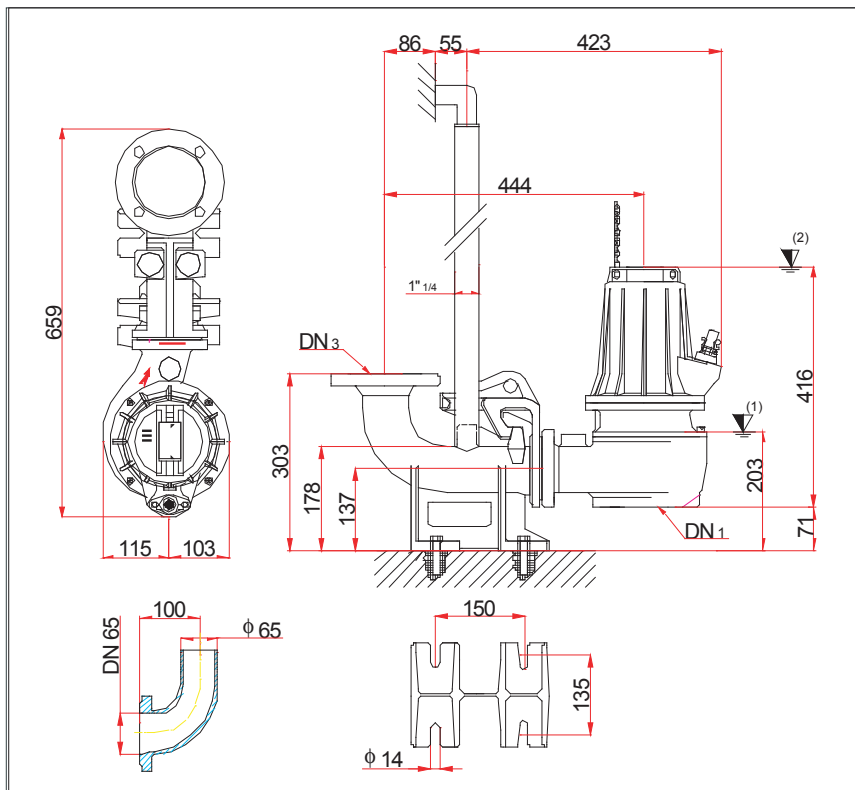

Dimensioni flange UNI
UNI flange dimensions

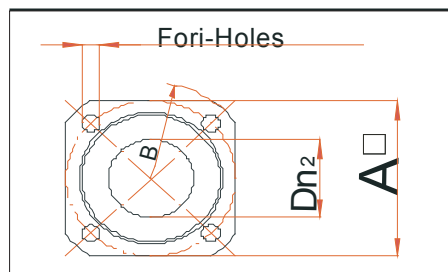

DIMENSIONI FLANGE UNI - UNI FLANGE DIMENSIONS

| TIPO - TYPE | DN 1 | DN 2/3 | A | B | Fori - Holes | | OPTIONAL | | | |
|---|------|--------|-----|-----|--------------|------|----------|----------|-------|--|
| | | | | | n° | φ mm | | | | |
| AM-AT 65/2/125 C.236 AT 65/2/125 C.237 | 65 | 65 | 130 | 160 | 4 | 14 | P4-DN 65 | B4-DN 65 | DN 65 | |

CARATTERISTICHE TECNICHE - TECHNICAL FEATURES

| TIPO - TYPE | CAVO - CABLE H07 - RNF | MT | Sonde termiche Thermal probes | | | | | |
|---|--------------------------------|----|---|-----------|--------------------|--------------------|--------------------|--------------------|
| | | | | si yes | Superiore Upper | Inferiore Lower | Superiore Upper | Inferiore Lower |
| AM-AT 65/2/125 C.236 AT 65/2/125 C.237 | (1) 7x1,5 φ 15 AVV. DIRETTO | 10 | Sonda di conduttività Conductivity probe | si yes | AR 20 | MG1S20//20-G26 | 6204 2Z | 3204 2Z |

NOTE - NOTES :

(1) Punto inferiore d'arresto nel caso di funzionamento automatico
Lowest shut-off point for automatic operation

(2) Sommergenza minima nel caso di funzionamento continuo
Minimum covering for continuous operation

AT 65/2/152 C. 247

On request

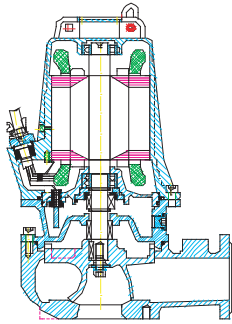

GIRANTE MONOCANALE
IMPELLER SINGLECHANNEL
ROUE MONOCANAL

| | |
|------------------|------|
| PASSAGGIO LIBERO | 45mm |
| FREE PASSAGE | 45mm |

| | |
|---------------|----------|
| ALBERO MOTORE | AISI 420 |
| MOTOR SHAFT | AISI 420 |

Curve secondo ISO 9906. Livello 2
Curves as per ISO 9906. Grade 2

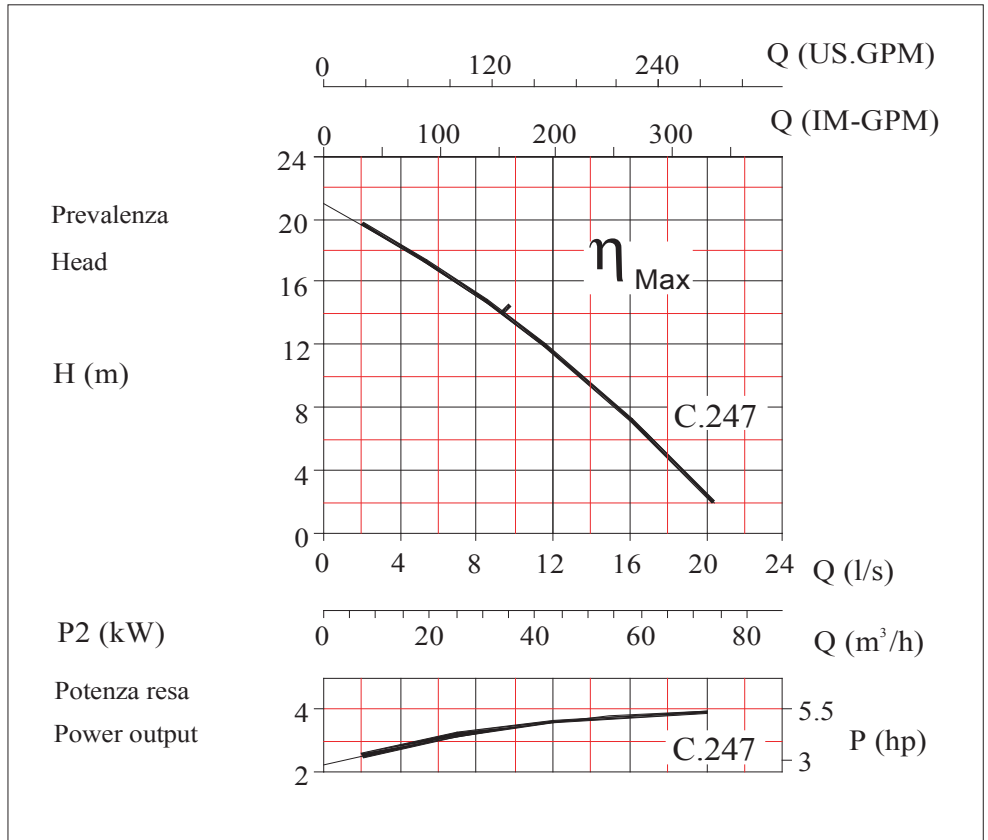

| Elettropompa Tipo Electric pump Type | Prevalenza - Head | | | | | | | | | | |
|---|--------------------|-----|-----|-----|----|------|-----|-----|-----|-----|-----|
| | Hm bar | | | | | | | | | | |
| | 2 | 4 | 6 | 8 | 10 | 12 | 14 | 16 | 18 | 20 | 22 |
| | Portata - Capacity | | | | | | | | | | |
| | Q (l/s) | | | | | | | | | | |
| | 0,2 | 0,4 | 0,6 | 0,8 | 1 | 1,2 | 1,4 | 1,6 | 1,8 | 2 | 2,2 |
| AT 65/2/152 C. 247 | 20,5 | 19 | 17 | 15 | 13 | 11,5 | 9 | 7 | 4 | 1,8 | |

Dati tecnici / Specifications

| | Mandata Delivery | kW | | r.p.m | Poles | Ampere | Hz | Cos φ |
|--------------------|---------------------|-----|----|-------|-------|--------------------|----|-------|
| | | P1 | P2 | 1/min | | Trifase 3~ 400V | | |
| AT 65/2/152 C. 247 | DN2 65 | 4,7 | 4 | 2850 | 2 | 9,0 | 50 | 0,9 |

Dimensioni di ingombro dell'imballo
Overall dimensions of packing

| TIPO-TYPE | X | Y | Z | Kg |
|--------------------|-----|-----|-----|----|
| AT 65/2/152 C. 247 | 340 | 550 | 420 | 60 |

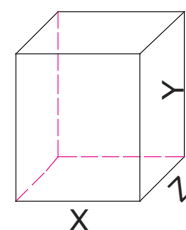

AT 65/2/152 C. 247



INSTALLAZIONE FISSA
STATIONARY INSTALLATION

INSTALLAZIONE MOBILE
MOBILE INSTALLATION

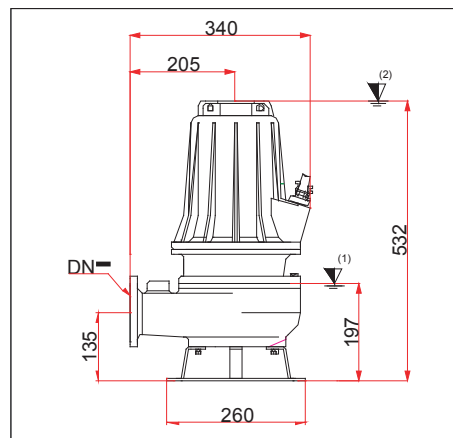
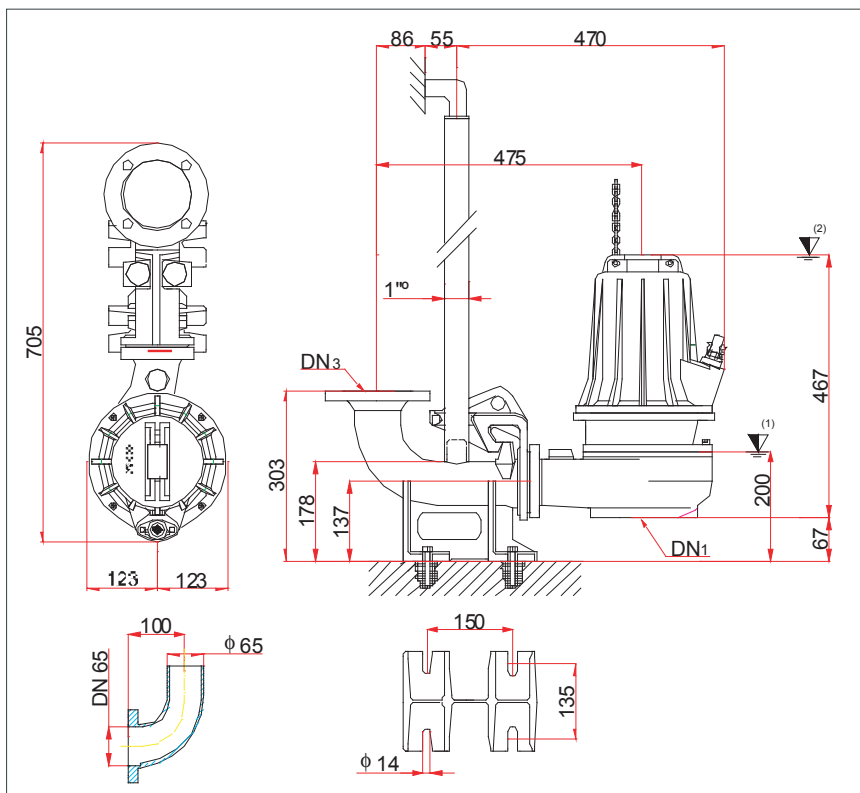

Dimensioni flange UNI
UNI flange dimensions

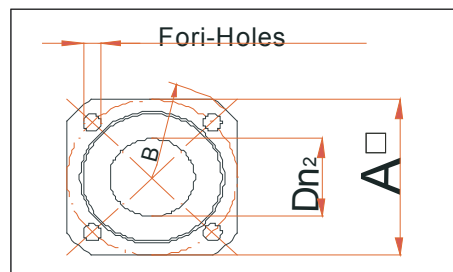

DIMENSIONI FLANGE UNI - UNI FLANGE DIMENSIONS

| TIPO - TYPE | DN 1 | DN 2/3 | A | B | Fori - Holes | | OPTIONAL | | | |
|-------------------|------|--------|-----|-----|--------------|------|----------|----------|-------|--|
| | | | | | n° | φ mm | | | | |
| AT 65/2/152 C.247 | 65 | 65 | 130 | 160 | 4 | 14 | P4-DN 65 | B4-DN 65 | DN 65 | |

CARATTERISTICHE TECNICHE - TECHNICAL FEATURES

| TIPO - TYPE | CAVO - CABLE H07 - RNF | MT | Sonde termiche | si | | | | |
|-------------------|--------------------------------|----|-----------------------|-----|--------------------|--------------------|--------------------|--------------------|
| | | | Thermal probes | yes | | | | |
| AT 65/2/152 C.247 | (1) 7x1,5 φ 15 AVV. DIRETTO | 10 | Sonda di conduttività | si | Superiore Upper | Inferiore Lower | Superiore Upper | Inferiore Lower |
| | | | Conductivity probe | yes | AR 25 | MG1/25 - G6 | 6205 2Z | 3205 2Z |

NOTE - NOTES :



Punto inferiore d'arresto nel caso di funzionamento automatico
Lowest shut-off point for automatic operation



Sommergenza minima nel caso di funzionamento continuo
Minimum covering for continuous operation

AT 80/2/173 C. 257

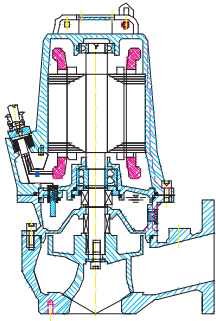

GIRANTE MONOCANALE
IMPELLER SINGLECHANNEL

| | |
|------------------|------|
| PASSAGGIO LIBERO | 55mm |
| FREE PASSAGE | 55mm |

| | |
|---------------|----------|
| ALBERO MOTORE | AISI 420 |
| MOTOR SHAFT | AISI 420 |

Curve secondo ISO 9906. Livello 2
Curves as per ISO 9906. Grade 2

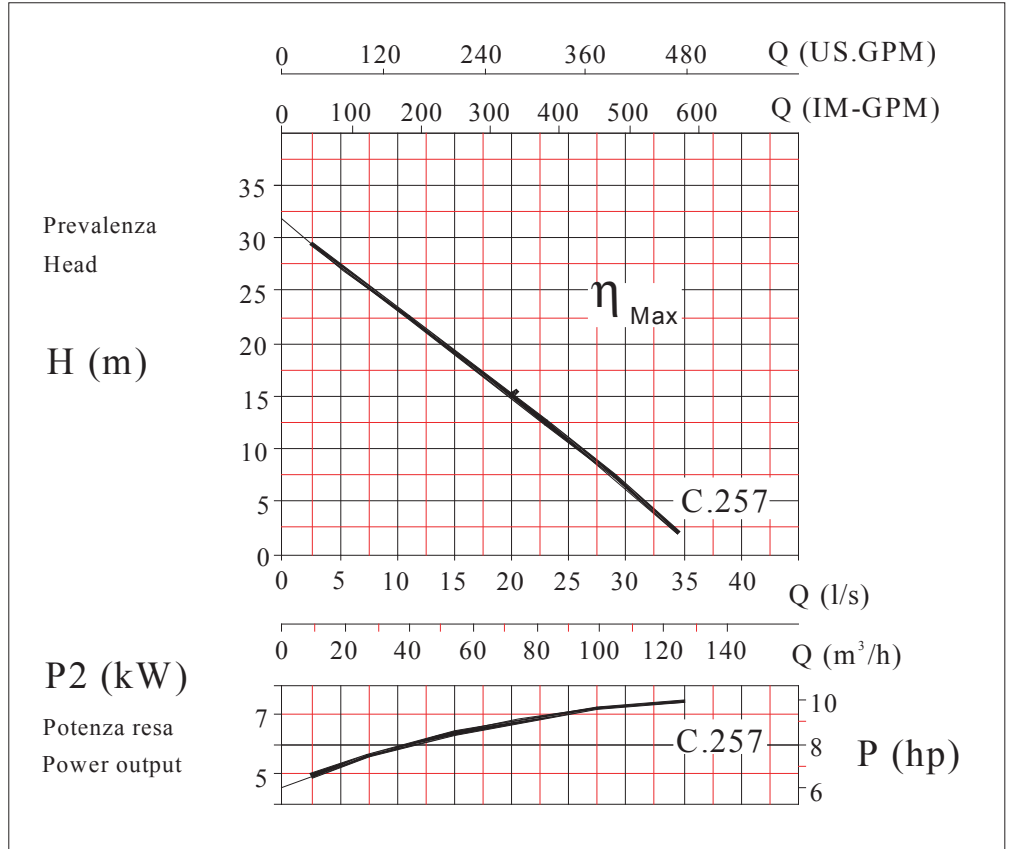

| Elettropompa Tipo Electric pump Type | Prevalenza - Head | | | | | | | | | |
|---|--------------------|-----|----|-----|------|-----|-----|-----|----|-----|
| | Hm bar | | | | | | | | | |
| | 2,5 | 5 | 10 | 15 | 20 | 25 | 30 | 35 | 40 | 45 |
| | 0,25 | 0,5 | 1 | 1,5 | 2 | 2,5 | 3 | 3,5 | 4 | 4,5 |
| AT 80/2/173 C. 257 | Portata - Capacity | | | | | | | | | |
| | Q (l/s) | | | | | | | | | |
| | 34 | 31 | 26 | 20 | 13,5 | 7,5 | 2,4 | | | |

Dati tecnici / Specifications

| | Mandata Delivery | kW | | r.p.m | Poles | Ampere | Hz | Cos φ |
|--------------------|------------------|-----|-----|-------|-------|--------------------|----|-------|
| | | P1 | P2 | 1/min | | Trifase 3~ 400V | | |
| AT 80/2/173 C. 257 | DN2 80 | 8,5 | 7,1 | 2850 | 2 | 14,1 | 50 | 0,87 |

Dimensioni di ingombro dell'imballo
Overall dimensions of packing

| TIPO-TYPE | X | Y | Z | Kg |
|--------------------|-----|-----|-----|------|
| AT 80/2/173 C. 257 | 340 | 550 | 420 | 87.5 |

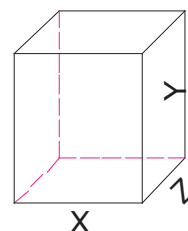

Dimensioni - Dimensions

AT 80/2/173 C. 257



INSTALLAZIONE FISSA
STATIONARY INSTALLATION

INSTALLAZIONE MOBILE
MOBILE INSTALLATION

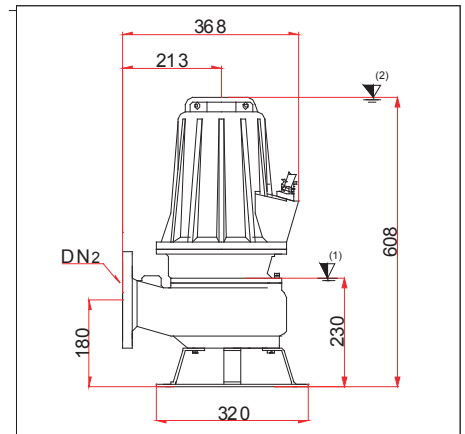
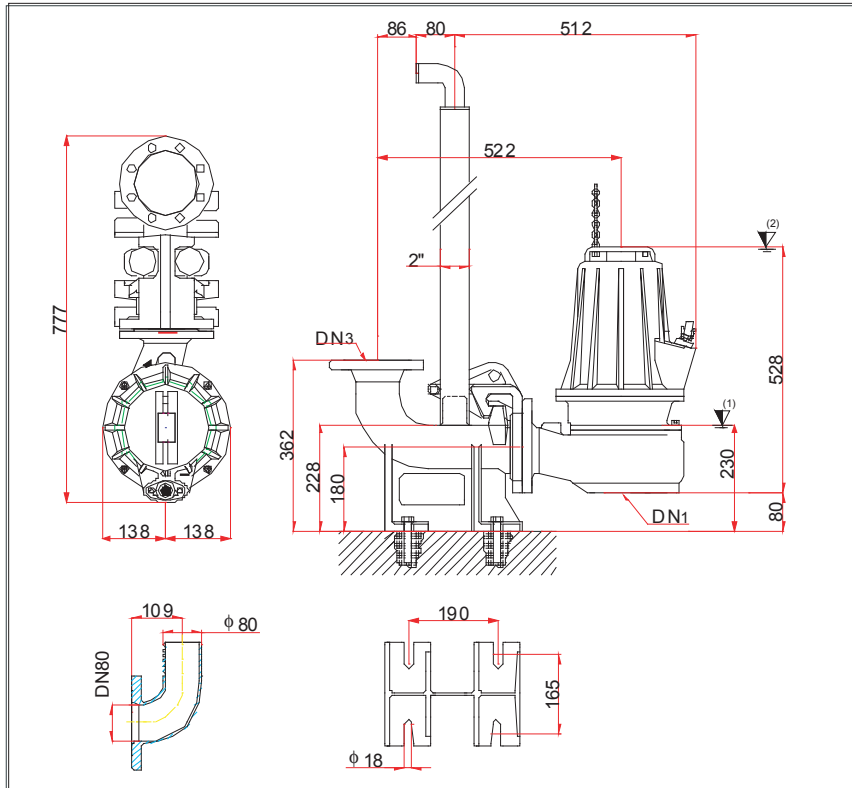

Dimensioni flange UNI
UNI flange dimensions

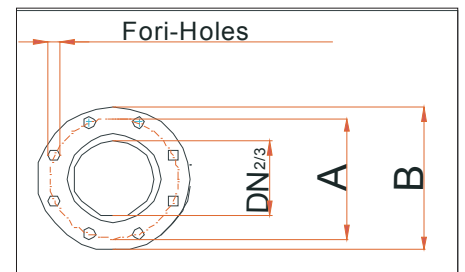

DIMENSIONI FLANGE UNI - UNI FLANGE DIMENSIONS

| TIPO - TYPE | DN 1 | DN 2/3 | A | B | Fori - Holes | | OPTIONAL | | | |
|-------------------|------|--------|-----|-----|--------------|------|----------|----------|---------------|--|
| | | | | | n° | φ mm | | | | |
| AT 80/2/173 C.257 | 80 | 80 | 160 | 200 | 8 | 18 | P5-DN 80 | B5-DN 80 | DN 80 - PN 16 | |

CARATTERISTICHE TECNICHE - TECHNICAL FEATURES

| TIPO - TYPE | CAVO - CABLE H07 - RNF | MT | Sonde termiche | si | | | | |
|-------------------|---------------------------|----|-----------------------|-----|-----------|-----------|-----------|-----------|
| | | | Thermal probes | yes | | | | |
| AT 80/2/173 C.257 | (1) 10x1,5 φ 20 Y-Δ | 10 | Sonda di conduttività | si | Superiore | Inferiore | Superiore | Inferiore |
| | | | Conductivity probe | yes | AR 30 | MG1/30/G6 | 6206 2Z | 3306 2Z |

NOTE - NOTES :

(1) Punto inferiore d'arresto nel caso di funzionamento automatico
Lowest shut-off point for automatic operation

(2) Sommergenza minima nel caso di funzionamento continuo
Minimum covering for continuous operation

AT 80/2/200 C. 267 - 268

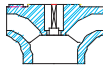
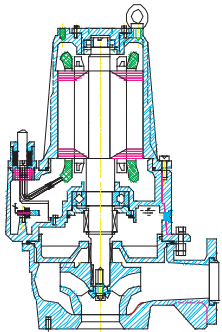

GIRANTE BICANALE
DOUBLE CHANNEL IMPELLER

| | |
|------------------|------|
| PASSAGGIO LIBERO | 33mm |
| FREE PASSAGE | 33mm |

| | |
|---------------|----------|
| ALBERO MOTORE | AISI 420 |
| MOTOR SHAFT | AISI 420 |

Curve secondo ISO 9906. Livello 2
Curves as per ISO 9906. Grade 2

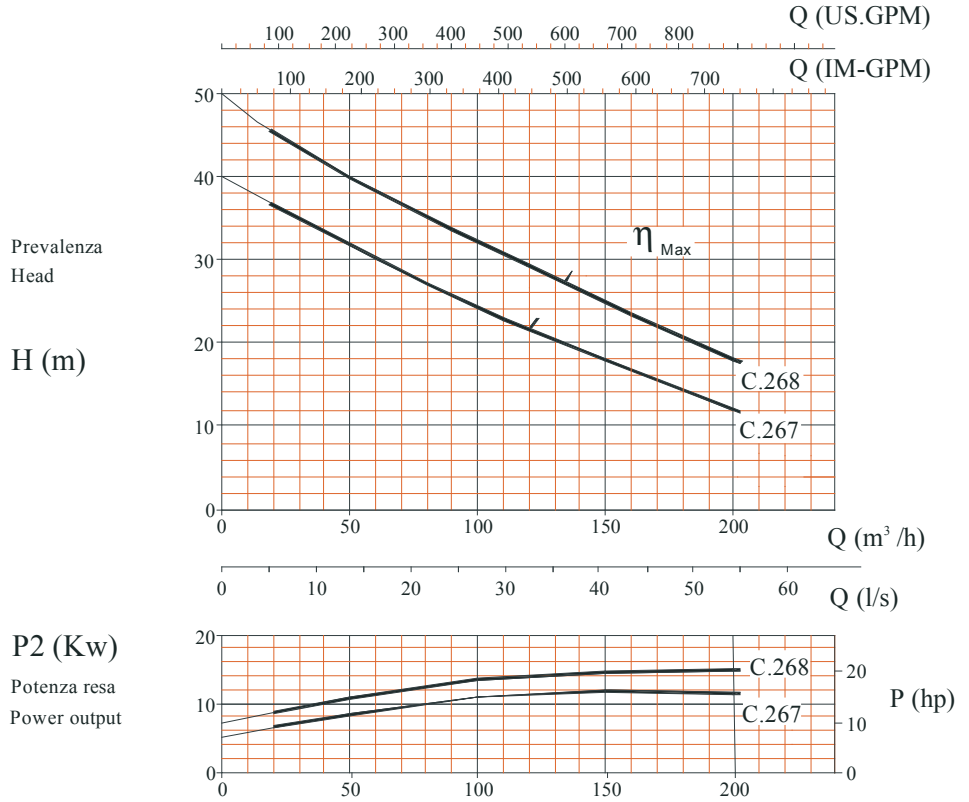

| Elettropompa Tipo Electric pump Type | Prevalenza - Head | | | | | | | | | | |
|---|--------------------|----|------|----|----|----|----|----|----|----|----|
| | Hm bar | | | | | | | | | | |
| | 10 | 15 | 20 | 25 | 30 | 35 | 40 | 45 | 50 | 55 | 60 |
| | Portata - Capacity | | | | | | | | | | |
| | Q (l/s) | | | | | | | | | | |
| AT 80/2/200 C. 267 | 62 | 47 | 35,5 | 25 | 16 | 8 | | | | | |
| AT 80/2/200 C. 268 | | 60 | 52 | 40 | 32 | 23 | 14 | 6 | | | |

Dati tecnici / Specifications

| | Mandata Delivery | kW | | r.p.m | Poles | Ampere | Hz | Cos φ |
|--------------------|------------------|------|------|-------|-------|------------|----|-------|
| | | P1 | P2 | 1/min | | Trifase 3~ | | |
| | | | | | | 400V | | |
| AT 80/2/200 C. 267 | DN2 80 | 14,8 | 11 | 2850 | 2 | 21 | 50 | 0,81 |
| AT 80/2/200 C. 268 | | 19,8 | 14,7 | 2850 | 2 | 31 | 50 | 0,89 |

Dimensioni di ingombro dell'imballo
Overall dimensions of packing

| TIPO-TYPE | X | Y | Z | Kg |
|--------------------|-----|-----|-----|-----|
| AT 80/2/200 C. 267 | 550 | 860 | 645 | 190 |
| AT 80/2/200 C. 268 | 550 | 860 | 645 | 200 |

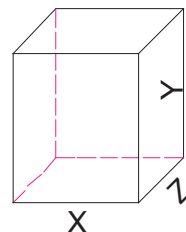

Dimensioni - Dimensions

AT 80/2/200 C. 267-268

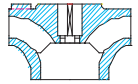

INSTALLAZIONE FISSA
STATIONARY INSTALLATION

INSTALLAZIONE MOBILE
MOBILE INSTALLATION

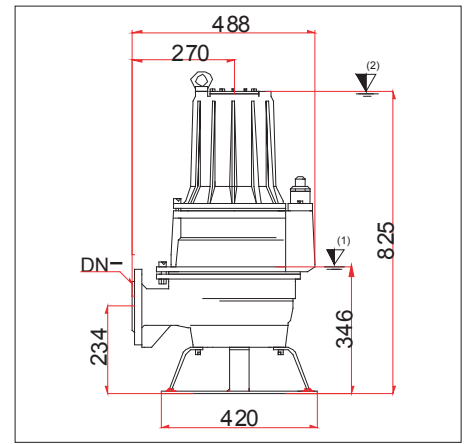
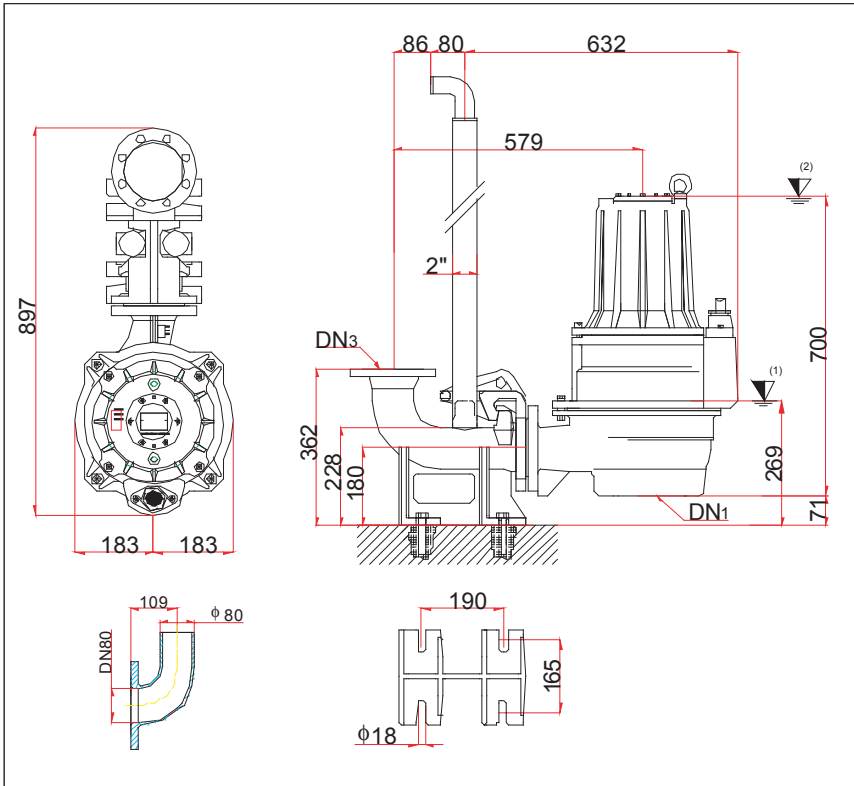

Dimensioni flange UNI
UNI flange dimensions

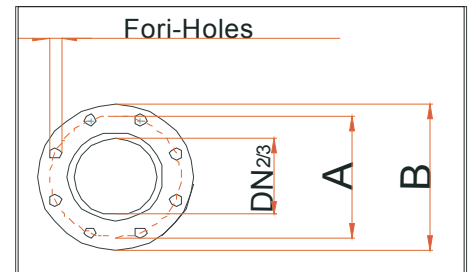

DIMENSIONI FLANGE UNI - UNI FLANGE DIMENSIONS

| TIPO - TYPE | DN 1 | DN 2/3 | A | B | Fori - Holes | | OPTIONAL | | | |
|--|------|--------|-----|-----|--------------|------|-----------|----------|---------------|--|
| | | | | | n° | φ mm | | | | |
| AT 80/2/200 C.267 AT 80/2/200 C.268 | 150 | 80 | 160 | 200 | 8 | 18 | P7-DN 150 | B5-DN 80 | DN 80 - PN 16 | |

GARANTISTICHE TECNICHE - TECHNICAL FEATURES

| TIPO - TYPE | CAVO - CABLE H07 - RNF | MT | Sonde termiche | si | | | | |
|---------------------------------------|---------------------------|----|-----------------------|-----|--------------------|--------------------|--------------------|--------------------|
| | | | Thermal probes | yes | | | | |
| AT 80/2/200 C.267 AT80/2/200 C.268 | (1) 10x2,5 φ 23 Y-Δ | 10 | Sonda di conduttività | si | Superiore Upper | Inferiore Lower | Superiore Upper | Inferiore Lower |
| | | | Conductivity probe | yes | MG1/55/G4 | MG1/40/G6 | NU 207EGJ33 | 6312 2RS1 |

NOTE - NOTES :

(1) Punto inferiore d'arresto nel caso di funzionamento automatico
Lowest shut-off point for automatic operation

(2) Sommergenza minima nel caso di funzionamento continuo
Minimum covering for continuous operation

AM - AT 80/4/125 C. 241- 242

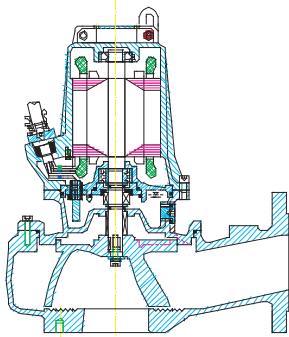

GIRANTE MONOCANALE
IMPELLER SINGLECHANNEL

| | |
|------------------|------|
| PASSAGGIO LIBERO | 75mm |
| FREE PASSAGE | 75mm |

| | |
|---------------|----------|
| ALBERO MOTORE | AISI 420 |
| MOTOR SHAFT | AISI 420 |

Curve secondo ISO 9906. Livello 2

Curves as per ISO 9906. Grade 2

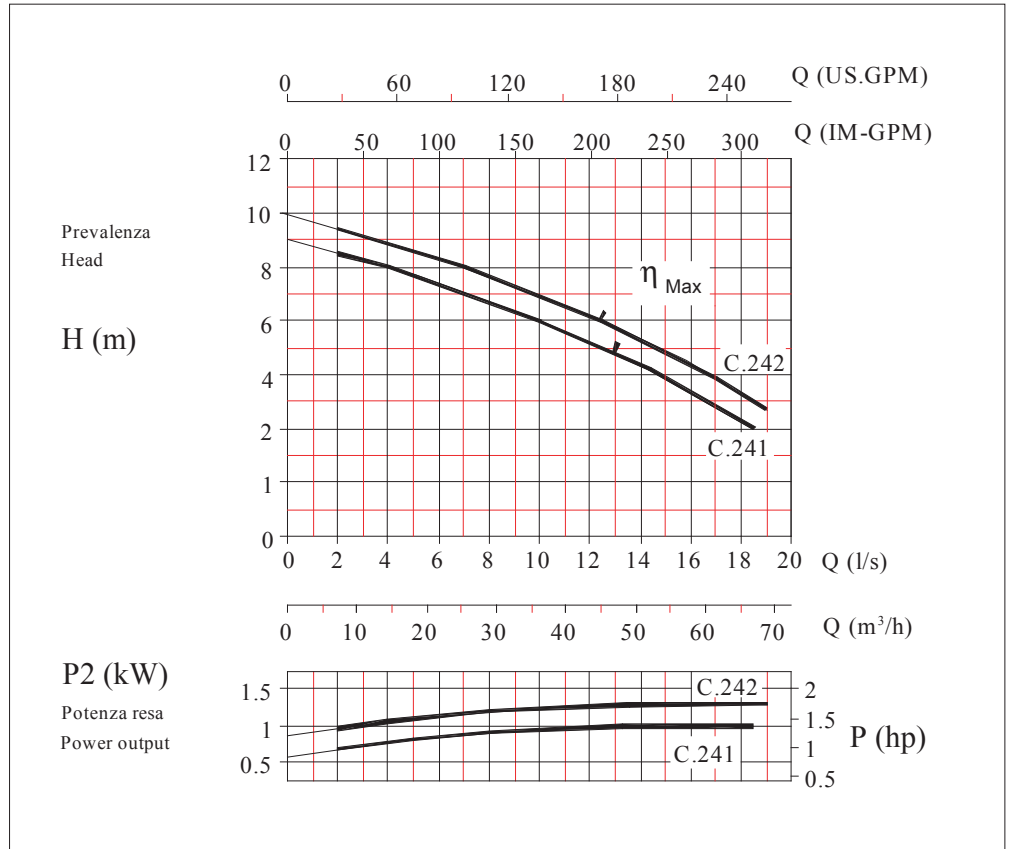

| Elettropompa Tipo Electric pump Type | Prevalenza - Head | | | | | | | | | | |
|---|--------------------|------|------|------|------|------|-----|-----|-----|----|-----|
| | $\frac{Hm}{bar}$ | | | | | | | | | | |
| | 1 | 2 | 3 | 4 | 5 | 6 | 7 | 8 | 9 | 10 | 11 |
| | 0,1 | 0,2 | 0,3 | 0,4 | 0,5 | 0,6 | 0,7 | 0,8 | 0,9 | 1 | 1,1 |
| | Portata - Capacity | | | | | | | | | | |
| | Q (l/s) | | | | | | | | | | |
| AM - AT 80/4/125 C. 241 | | 18,5 | 16,8 | 14,7 | 12,5 | 10 | 7 | 4 | | | |
| AM - AT 80/4/125 C. 242 | | | 18,5 | 17 | 14,5 | 12,5 | 9,5 | 7 | 3,5 | | |

Dati tecnici / Specifications

| | Mandata Delivery | kW | | r.p.m. | Poles | Hz | Ampere | | | Cos φ |
|----------------------|---------------------|----------------------|------|--------|-------|------|--------|-----|---------|-------|
| | | P1 | P2 | 1/min | | | 230 V | uf | 400V 3~ | |
| | | AM-AT 80/4/125 C.241 | 1,5 | 1,9 | | | 1450 | 4 | 50 | |
| AM-AT 80/4/125 C.242 | 1,8 | 1,25 | 1450 | 4 | 50 | 12,5 | 50 | 3,2 | 0,83 | |

Dimensioni di ingombro dell'imballo
Overall dimensions of packing

| TIPO-TYPE | X | Y | Z | Kg |
|-------------------------|-----|-----|-----|----|
| AM - AT 80/4/125 C. 241 | 340 | 550 | 420 | 57 |
| AM - AT 80/4/125 C. 242 | 340 | 550 | 420 | 57 |

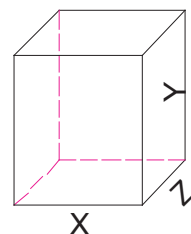

Dimensioni - Dimensions

AM - AT 80/4/125 C.241-242



INSTALLAZIONE FISSA
STATIONARY INSTALLATION

INSTALLAZIONE MOBILE
MOBILE INSTALLATION

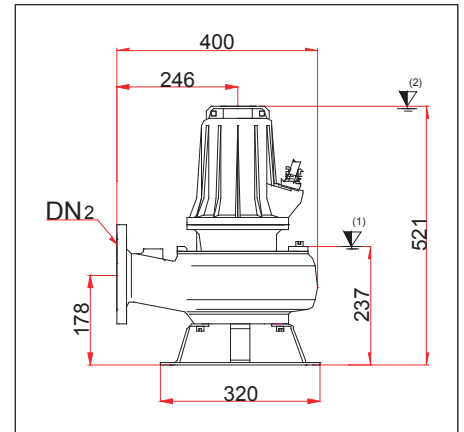
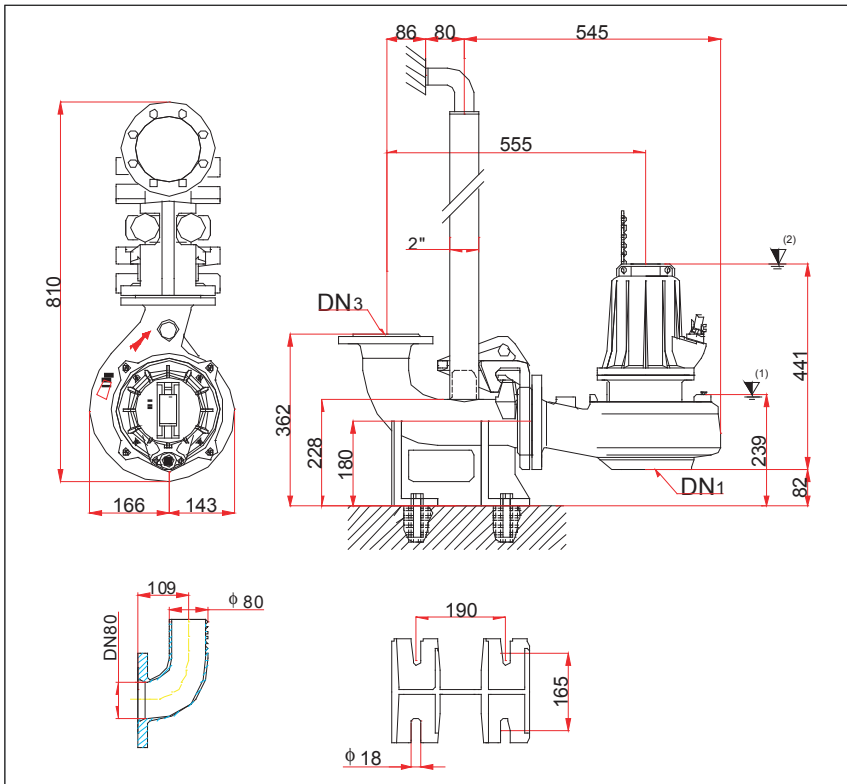

Dimensioni flange UNI
UNI flange dimensions

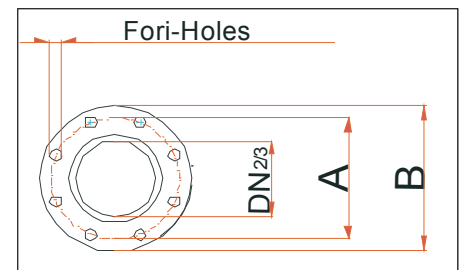

DIMENSIONI FLANGE UNI - UNI FLANGE DIMENSIONS

| TIPO - TYPE | DN 1 | DN 2/3 | A | B | Fori - Holes | | OPTIONAL | | | |
|--|------|--------|-----|-----|--------------|------|----------|--|--|--|
| | | | | | n° | φ mm | | | | |
| AM-AT 80/4/125 C.241 AM-AT 80/4/125 C.242 | 80 | 80 | 160 | 200 | 8 | 18 | | | | |

CARATTERISTICHE TECNICHE - TECHNICAL FEATURES

| TIPO - TYPE | CAVO - CABLE H07 - RNF | MT | Sonde termiche | | | | | |
|--|--------------------------------|----|-----------------------|-----|-----------|-----------------|-----------|-----------|
| | | | Thermal probes | si | | | | |
| AM-AT 80/4/125 C.241 AM-AT 80/4/125 C.242 | (1) 7x1,5 φ 15 AVV. DIRETTO | 10 | Sonda di conduttività | si | Superiore | Inferiore | Superiore | Inferiore |
| | | | Conductivity probe | yes | Upper | Lower | Upper | Lower |
| | | | | | AR 20 | M G1S2 02 0-G26 | 6204 2Z | 3204 2Z |

NOTE - NOTES :

(1) Punto inferiore d'arresto nel caso di funzionamento automatico
Lowest shut-off point for automatic operation

(2) Sommergenza minima nel caso di funzionamento continuo
Minimum covering for continuous operation

AT 80/4/152 C. 243 - 244 - 245

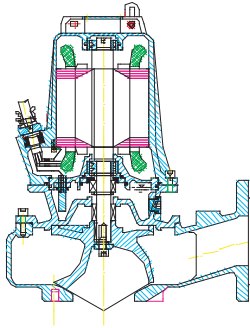

GIRANTE MONOCANALE
IMPELLER SINGLECHANNEL



| | |
|------------------|------|
| PASSAGGIO LIBERO | 75mm |
| FREE PASSAGE | 75mm |

| | |
|---------------|----------|
| ALBERO MOTORE | AISI 420 |
| MOTOR SHAFT | AISI 420 |

Curve secondo ISO 9906. Livello 2
Curves as per ISO 9906. Grade 2

Prevalenza
Head

H (m)

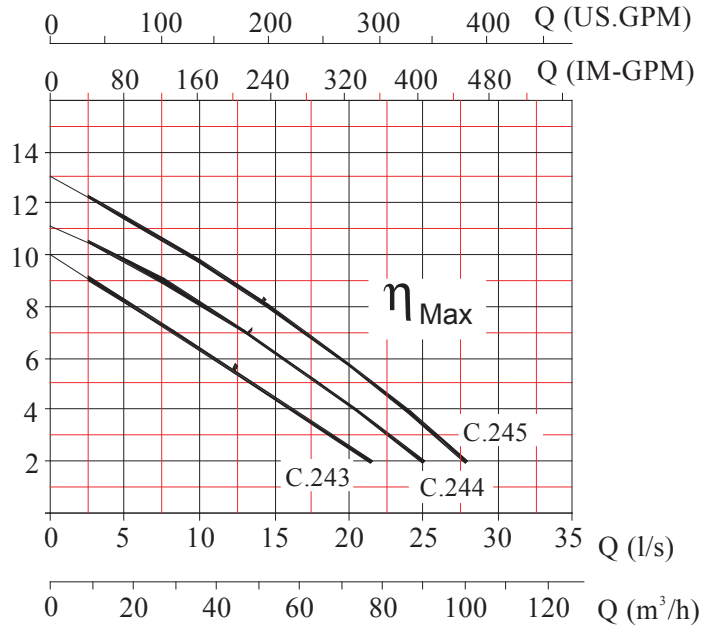

P2 (kW)
Potenza resa
Power output

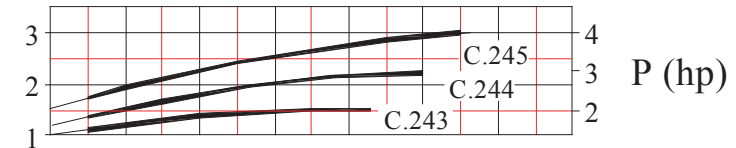

| Elettropompa Tipo Electric pump Type | Prevalenza - Head | | | | | | | | | | |
|---|-------------------|-----|------|-----|------|-----|-----|----|-----|-----|-----|
| | Hm bar | | | | | | | | | | |
| | 1 | 2 | 3 | 4 | 5 | 6 | 8 | 10 | 11 | 12 | 13 |
| | 0,1 | 0,2 | 0,3 | 0,4 | 0,5 | 0,6 | 0,8 | 1 | 1,1 | 1,2 | 1,3 |
| Portata - Capacity | | | | | | | | | | | |
| Q (l/s) | | | | | | | | | | | |
| AT 80/4/152 C. 243 | | 22 | 19 | 16 | 14 | 11 | 5,5 | | | | |
| AT 80/4/152 C. 244 | | 25 | 22,5 | 20 | 18 | 15 | 10 | 4 | | | |
| AT 80/4/152 C. 245 | | 28 | 26 | 24 | 21,5 | 19 | 14 | 9 | 6 | 3 | |

Dati tecnici / Specifications

| | Mandata Delivery | kW | | r.p.m | Poles | Ampere | Hz | Cos φ |
|--------------------|---------------------|-----|-----|-------|-------|------------|----|-------|
| | | P1 | P2 | 1/min | | Trifase 3~ | | |
| | | | | | | 400V | | |
| AT 80/4/152 C. 243 | DN2 80 | 2,3 | 1,5 | 1450 | 4 | 4,0 | 50 | 0,85 |
| AT 80/4/152 C. 244 | | 3,0 | 2,2 | 1450 | 4 | 5,0 | 50 | 0,86 |
| AT 80/4/152 C. 245 | | 3,6 | 3 | 1450 | 4 | 6,4 | 50 | 0,85 |

Dimensioni di ingombro dell'imballo
Overall dimensions of packing

| TIPO-TYPE | X | Y | Z | Kg |
|--------------------|-----|-----|-----|----|
| AT 80/4/152 C. 243 | 340 | 550 | 420 | 67 |
| AT 80/4/152 C. 244 | 340 | 550 | 420 | 69 |
| AT 80/4/152 C. 245 | 340 | 550 | 420 | 70 |

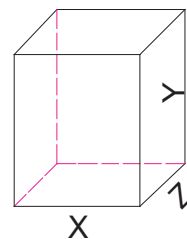

Dimensioni - Dimensions

AT 80/4/152 C.243-244-245



INSTALLAZIONE FISSA
STATIONARY INSTALLATION

INSTALLAZIONE MOBILE
MOBILE INSTALLATION

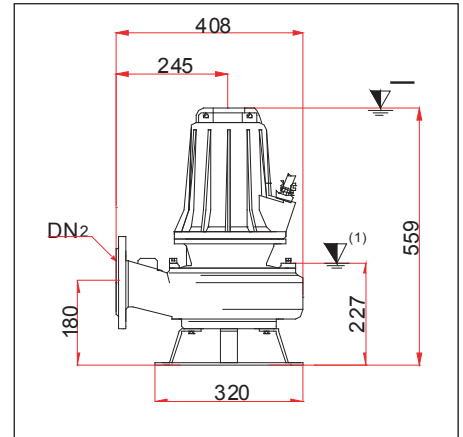
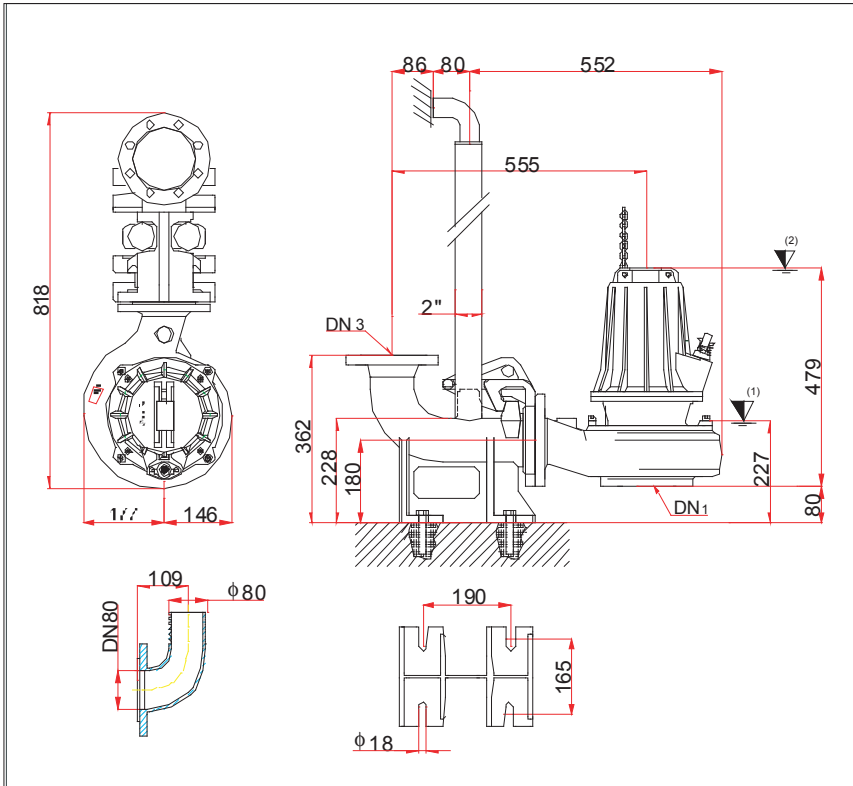

Dimensioni flange UNI
UNI flange dimensions

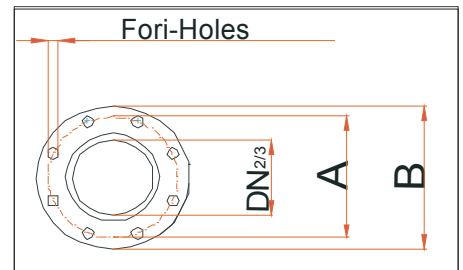

DIMENSIONI FLANGE UNI - UNI FLANGE DIMENSIONS

| TIPO - TYPE | DN 1 | DN 2/3 | A | B | Fori - Holes | | OPTIONAL | | | |
|---|------|--------|-----|-----|--------------|------|----------|----------|---------------|--|
| | | | | | n° | φ mm | | | | |
| AT 80/4/152 C.243 AT 80/4/152 C.244 AT 80/4/152 C.245 | 80 | 80 | 160 | 200 | 8 | 18 | P5-DN 80 | B5-DN 80 | DN 80 - PN 16 | |

CARATTERISTICHE TECNICHE - TECHNICAL FEATURES

| TIPO - TYPE | CAVO - CABLE H07 - RNF | MT | Sonde termiche | si | | | | |
|--|--------------------------------|----|-----------------------|-----|-----------|-------------|-----------|-----------|
| | | | Thermal probes | yes | | | | |
| AT 80-4-152 C. 243 AT 80-4-152 C. 244 AT 80-4-152 C. 245 | (1) 7x1,5 φ 15 AVV. DIRETTO | 10 | Sonda di conduttività | si | Superiore | Inferiore | Superiore | Inferiore |
| | | | Conductivity probe | yes | AR 25 | MG1/25 - G6 | 6205 2Z | 3205 2Z |

NOTE - NOTES :

(1) Punto inferiore d'arresto nel caso di funzionamento automatico
Lowest shut-off point for automatic operation

(2) Sommergenza minima nel caso di funzionamento continuo
Minimum covering for continuous operation

AT 100/4/152 c.243-244-245

On request

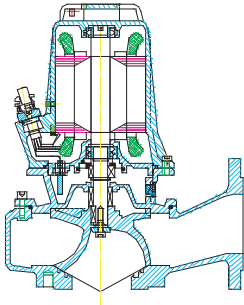

GIRANTE MONOCANALE
IMPELLER SINGLECHANNEL



| | |
|------------------|------|
| PASSAGGIO LIBERO | 90mm |
| FREE PASSAGE | 90mm |

| | |
|---------------|----------|
| ALBERO MOTORE | AISI 420 |
| MOTOR SHAFT | AISI 420 |

Curve secondo ISO 9906. Livello 2
Curves as per ISO 9906. Grade 2

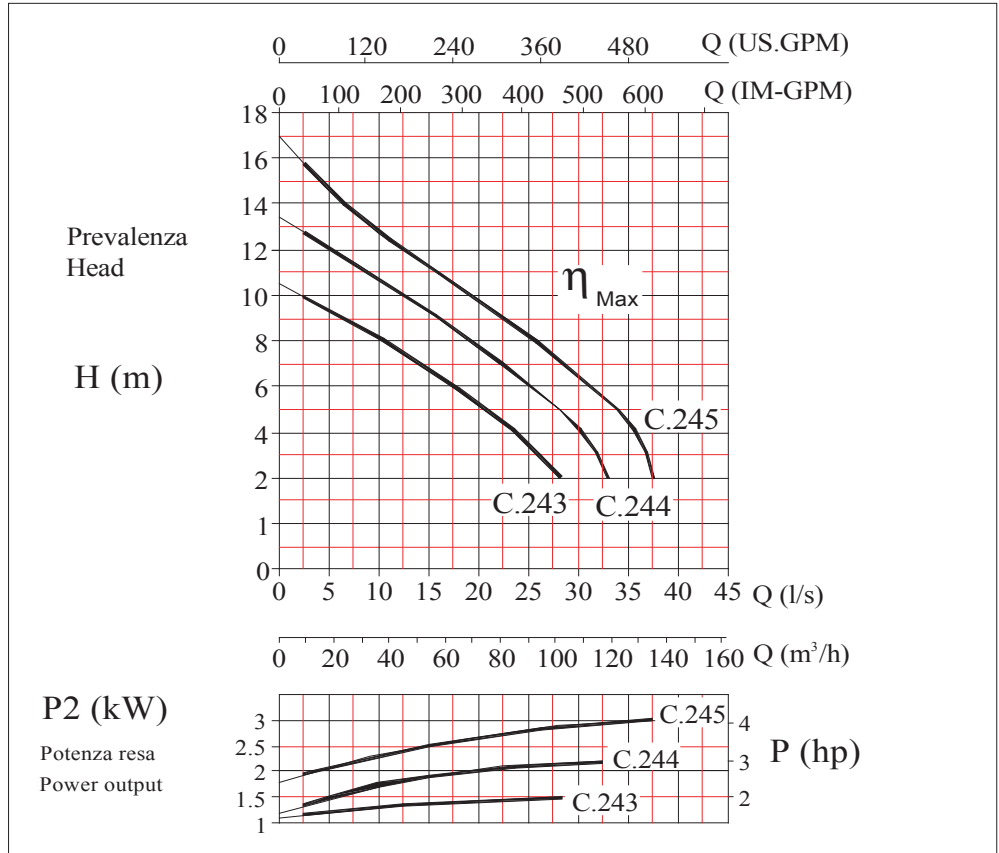

| Elettropompa Tipo Electric pump Type | Prevalenza - Head | | | | | | | | | | |
|---|-------------------|-----|-----|-----|------|-----|------|------|-----|-----|-----|
| | Hm bar | | | | | | | | | | |
| | 2 | 3 | 4 | 5 | 6 | 8 | 10 | 12 | 14 | 16 | 18 |
| | 0,2 | 0,3 | 0,4 | 0,5 | 0,6 | 0,8 | 1 | 1,2 | 1,4 | 1,6 | 1,8 |
| Portata - Capacity | | | | | | | | | | | |
| | Q (l/s) | | | | | | | | | | |
| AT 100/4/152 C. 243 | 28 | 26 | 23 | 21 | 17,5 | 10 | 2,5 | | | | |
| AT 100/4/152 C. 244 | 33 | 32 | 30 | 26 | 25 | 19 | 12,5 | 5 | | | |
| AT 100/4/152 C. 245 | 37,5 | 37 | 36 | 34 | 31,5 | 26 | 19 | 12,5 | 6,5 | 2 | |

Dati tecnici / Specifications

| | Mandata Delivery | kW | | r.p.m | Poles | Ampere | Hz | Cos φ |
|---------------------|---------------------|-----|-----|-------|-------|------------|----|-------|
| | | P1 | P2 | 1/min | | Trifase 3~ | | |
| | | | | | | 400V | | |
| AT 100/4/152 C. 243 | DN2 100 | 2,4 | 1,5 | 1450 | 4 | 4,2 | 50 | 0,82 |
| AT 100/4/152 C. 244 | | 3,0 | 2,2 | 1450 | 4 | 4,7 | 50 | 0,84 |
| AT 100/4/152 C. 245 | | 3,6 | 3 | 1450 | 4 | 6,5 | 50 | 0,81 |

Dimensioni di ingombro dell'imballo
Overall dimensions of packing

| TIPO-TYPE | X | Y | Z | Kg |
|---------------------|-----|-----|-----|------|
| AT 100/4/152 C. 243 | 400 | 620 | 465 | 71,5 |
| AT 100/4/152 C. 244 | 400 | 620 | 465 | 73,5 |
| AT 100/4/152 C. 245 | 400 | 620 | 465 | 75 |

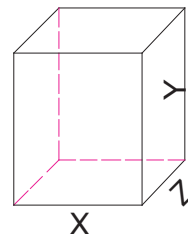

AT 100/4/152 C.243-244-245



INSTALLAZIONE FISSA
STATIONARY INSTALLATION

INSTALLAZIONE MOBILE
MOBILE INSTALLATION

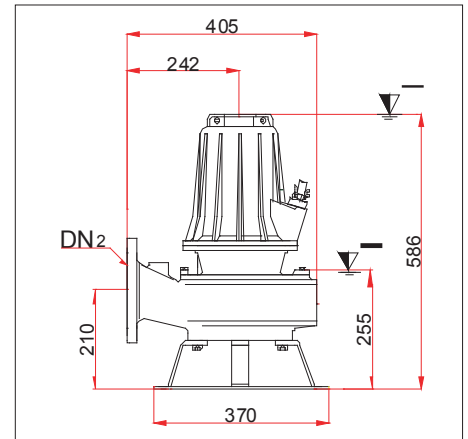
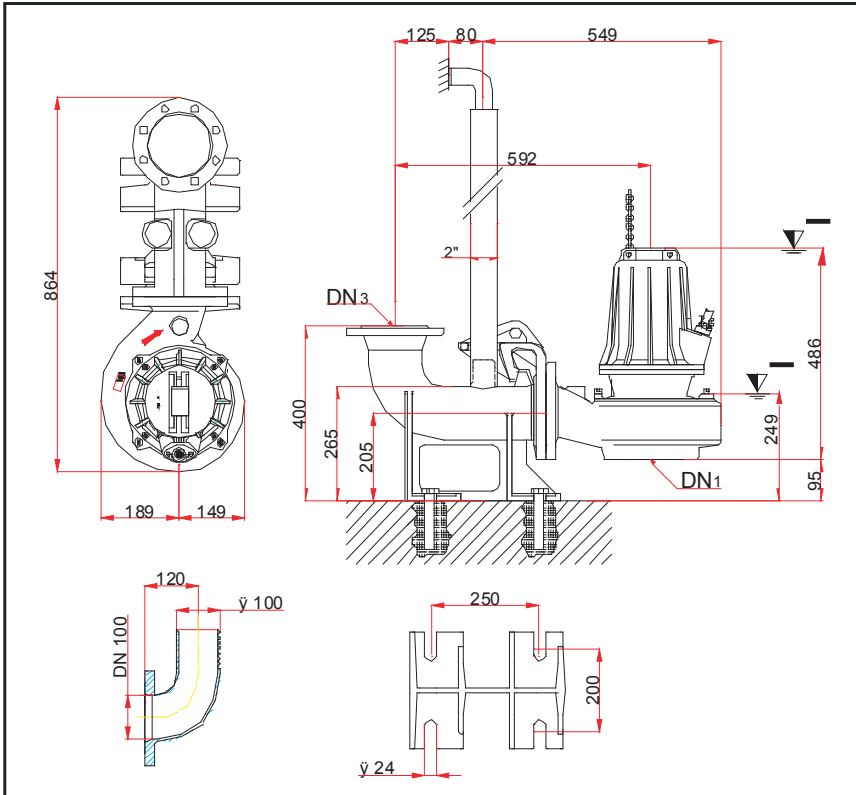

Dimensioni flange UNI
UNI flange dimensions

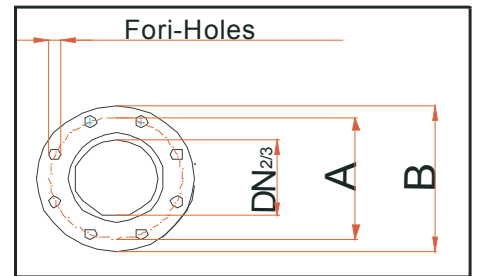

DIMENSIONI FLANGE UNI - UNI FLANGE DIMENSIONS

| TIPO - TYPE | DN 1 | DN 2/3 | A | B | Fori - Holes | | OPTIONAL | | | |
|--|------|--------|-----|-----|--------------|------|-----------|-----------|----------------|--|
| | | | | | n° | φ mm | | | DN 100 - PN 16 | |
| AT 100/4/152 C.243 AT 100/4/152 C.244 AT 100/4/152 C.245 | 100 | 100 | 180 | 220 | 8 | 18 | P6-DN 100 | B6-DN 100 | DN 100 - PN 16 | |

CARATTERISTICHE TECNICHE - TECHNICAL FEATURES

| TIPO - TYPE | CAVO - CABLE H07 - RNF | MT | Sonde termiche Thermal probes | | | | | | |
|--|--------------------------------|----|---|-----------|--------------------|--------------------|--------------------|--------------------|--|
| | | | si yes | | Superiore Upper | Inferiore Lower | Superiore Upper | Inferiore Lower | |
| AT 100/4/152 C.243 AT 100/4/152 C.244 AT 100/4/152 C.245 | (1) 7x1,5 φ 15 AVV. DIRETTO | 10 | | | | | | | |
| | | | Sonda di conduttività Conductivity probe | si yes | | | | | |
| | | | | | AR 25 | MG1/25 - G6 | 6205 2Z | 3205 2Z | |

NOTE - NOTES :

(1) Punto inferiore d'arresto nel caso di funzionamento automatico
Lowest shut-off point for automatic operation

(2) Sommergenza minima nel caso di funzionamento continuo
Minimum covering for continuous operation

AT 100/4/173 C. 255-256

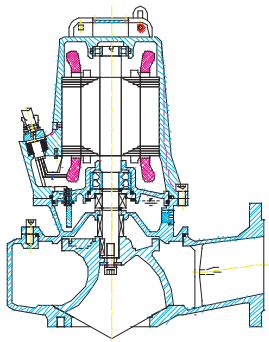

GIRANTE MONOCANALE
IMPELLER SINGLECHANNEL



| | |
|------------------|------|
| PASSAGGIO LIBERO | 90mm |
| FREE PASSAGE | 90mm |

| | |
|---------------|----------|
| ALBERO MOTORE | AISI 420 |
| MOTOR SHAFT | AISI 420 |

Curve secondo ISO 9906. Livello 2
Curves as per ISO 9906. Grade 2

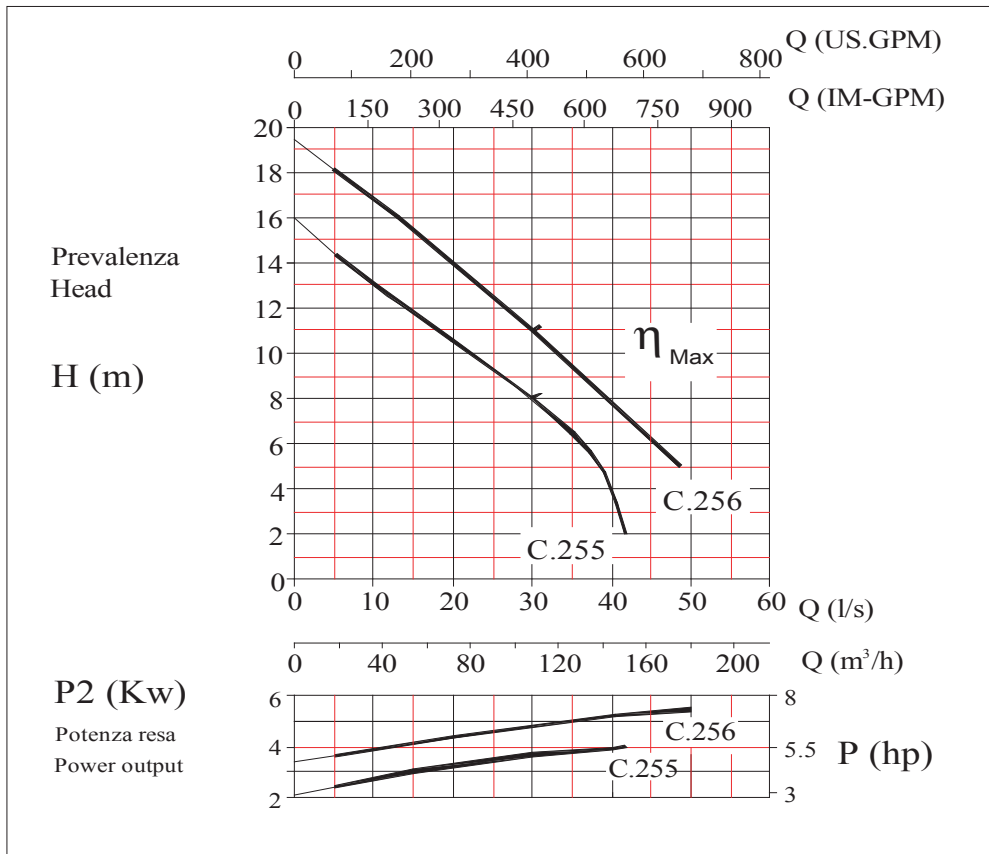

| Elettropompa Tipo Electric pump Type | Prevalenza - Head | | | | | | | | | | |
|---|--------------------|-----|-----|------|------|-----|----|------|-----|-----|-----|
| | Hm bar | | | | | | | | | | |
| | 2 | 3 | 4 | 6 | 7 | 8 | 10 | 12 | 14 | 16 | 18 |
| | 0,2 | 0,3 | 0,4 | 0,6 | 0,7 | 0,8 | 1 | 1,2 | 1,4 | 1,6 | 1,8 |
| | Portata - Capacity | | | | | | | | | | |
| | Q (l/s) | | | | | | | | | | |
| AT 100/4/173 C. 255 | 42 | 41 | 40 | 36,5 | 33 | 30 | 23 | 14 | 6 | | |
| AT 100/4/173 C. 256 | | | | 45 | 42,5 | 39 | 33 | 26,5 | 20 | 13 | 5 |

Dati tecnici / Specifications

| | Mandata Delivery | kW | | r.p.m | Poles | Ampere | Hz | Cos φ |
|---------------------|------------------|-----|-----|-------|-------|------------|----|-------|
| | | P1 | P2 | 1/min | | Trifase 3~ | | |
| | | | | | | 400V | | |
| AT 100/4/173 C. 255 | DN2 100 | 4,5 | 4 | 1450 | 4 | 7,8 | 50 | 0,83 |
| AT 100/4/173 C. 256 | | 6,3 | 5,5 | 1450 | 4 | 11,6 | 50 | 0,79 |

Dimensioni di ingombro dell'imballo
Overall dimensions of packing

| TIPO-TYPE | X | Y | Z | Kg |
|---------------------|-----|-----|-----|-----|
| AT 100/4/173 C. 255 | 400 | 620 | 465 | 97 |
| AT 100/4/173 C. 256 | 400 | 620 | 465 | 103 |

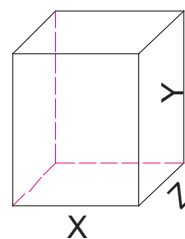

Dimensioni - Dimensions

AT 100/4/173 C.255-256



INSTALLAZIONE FISSA
STATIONARY INSTALLATION

INSTALLAZIONE MOBILE
MOBILE INSTALLATION

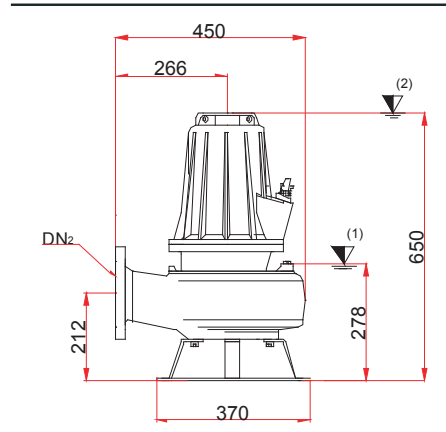
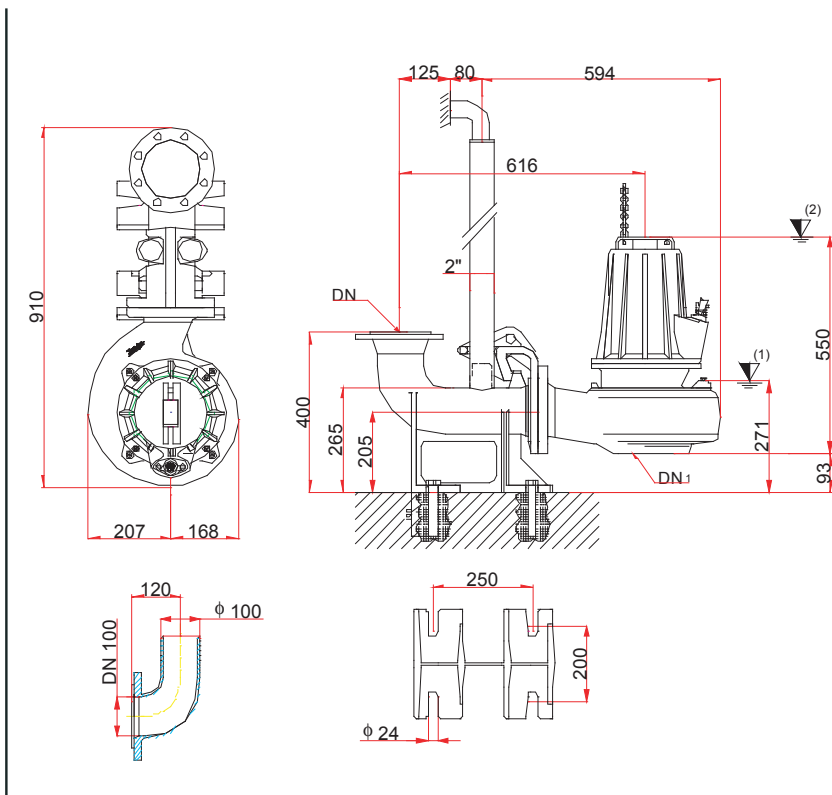

Dimensioni flange UNI
UNI flange dimensions

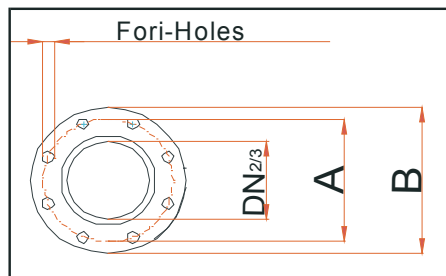

DIMENSIONI FLANGE UNI - UNI FLANGE DIMENSIONS

| TIPO - TYPE | DN 1 | DN 2/3 | A | B | Fori - Holes | | OPTIONAL | | | |
|--|------|--------|-----|-----|--------------|------|-----------|-----------|----------------|--|
| | | | | | n° | φ mm | | | | |
| AT 100-4-173 C.255 AT 100-4-173 C.256 | 100 | 100 | 180 | 220 | 8 | 18 | P6-DN 100 | B6-DN 100 | DN 100 - PN 16 | |

CARATTERISTICHE TECNICHE - TECHNICAL FEATURES

| TIPO - TYPE | CAVO - CABLE H07 - RNF | MT | Sonde termiche | si | | | | |
|--|---------------------------|----|-----------------------|-----|--------------------|--------------------|--------------------|--------------------|
| | | | Thermal probes | yes | Superiore Upper | Inferiore Lower | Superiore Upper | Inferiore Lower |
| AT 100-4-173 C.255 AT 100-4-173 C.256 | (1) 10x1,5 φ 20 Y-△ | 10 | Sonda di conduttività | si | AR30 | MG1/30/G6 | 6206 2Z | 3306 2Z |
| | | | Conductivity probe | yes | | | | |

NOTE - NOTES :



Punto inferiore d'arresto nel caso di funzionamento automatico
Lowest shut-off point for automatic operation



Sommergenza minima nel caso di funzionamento continuo
Minimum covering for continuous operation

AT 150/4/173 C. 258

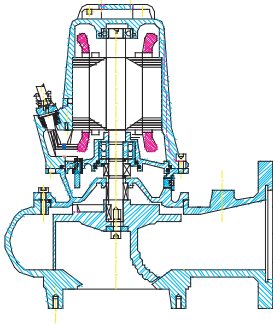

GIRANTE MONOCANALE
IMPELLER SINGLECHANNEL



| | |
|------------------|-------|
| PASSAGGIO LIBERO | 100mm |
| FREE PASSAGE | 100mm |

| | |
|---------------|----------|
| ALBERO MOTORE | AISI 420 |
| MOTOR SHAFT | AISI 420 |

Curve secondo ISO 9906. Livello 2
Curves as per ISO 9906. Grade 2

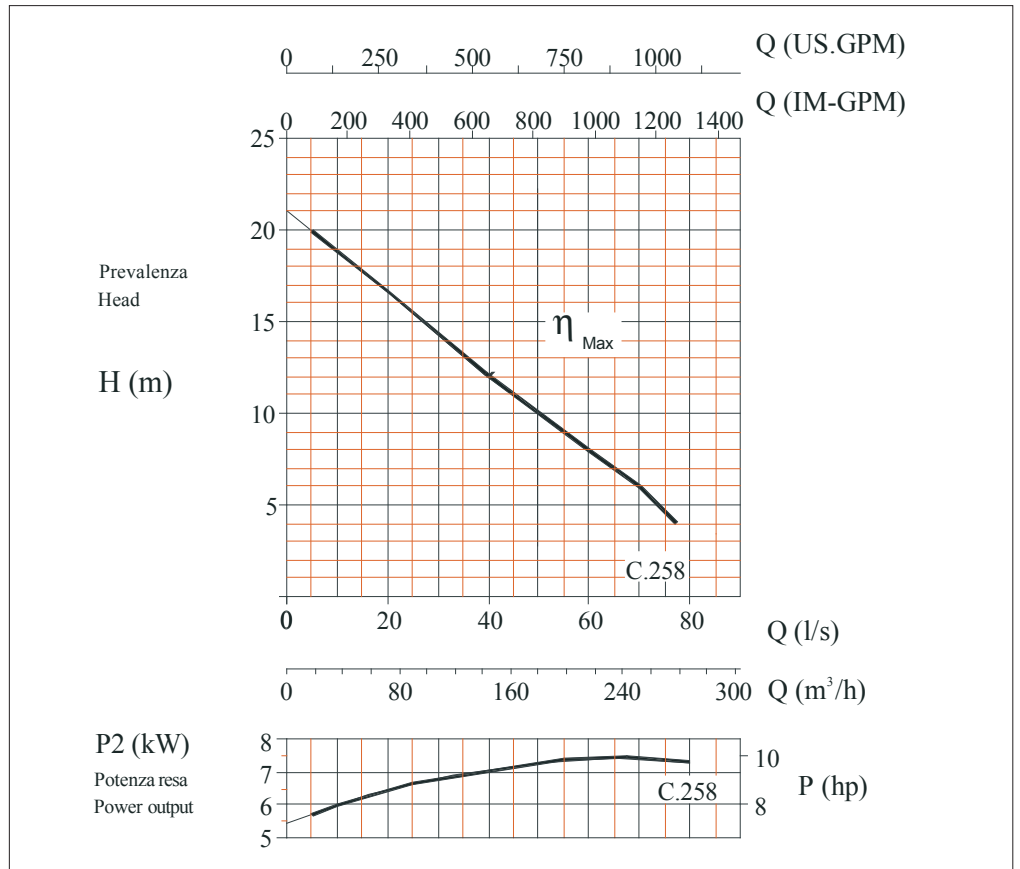

| Elettropompa Tipo Electric pump Type Electropompe Type | Prevalenza - Head | | | | | | | | | | |
|--|--------------------|-----|-----|----|-----|-----|-----|-----|----|-----|-----|
| | Hm bar | | | | | | | | | | |
| | 4 | 6 | 8 | 10 | 12 | 14 | 16 | 18 | 20 | 22 | 24 |
| | 0,4 | 0,6 | 0,8 | 1 | 1,2 | 1,4 | 1,6 | 1,8 | 2 | 2,2 | 2,4 |
| AT 150/4/173 C. 258 | Portata - Capacity | | | | | | | | | | |
| | Q (l/s) | | | | | | | | | | |
| | 77 | 70 | 60 | 50 | 40 | 31 | 22 | 14 | 5 | | |

Dati tecnici / Specifications

| | Mandata Delivery | kW | | r.p.m | Poles | Ampere | Hz | Cos φ |
|---------------------|---------------------|----|-----|-------|-------|--------------------|----|-------|
| | | P1 | P2 | 1/min | | Trifase 3~ 400V | | |
| AT 150/4/173 C. 258 | DN2 150 | 10 | 7.5 | 1450 | 4 | 15.2 | 50 | 0,87 |

Dimensioni di ingombro dell'imballo
Overall dimensions of packing

| TIPO-TYPE | X | Y | Z | Kg |
|---------------------|-----|-----|-----|-------|
| AT 150/4/173 C. 258 | 530 | 620 | 420 | 122,5 |

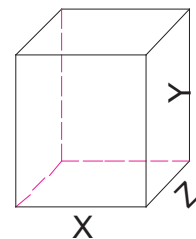

Specifiche costruttive disegni e fotografie sono Modificabili senza alcun preavviso
Constructive specifications designs and photos are modifiable without any notice

Dimensioni - Dimensions

AT 150/4/173 C.258



INSTALLAZIONE FISSA
STATIONARY INSTALLATION

INSTALLAZIONE MOBILE
MOBILE INSTALLATION

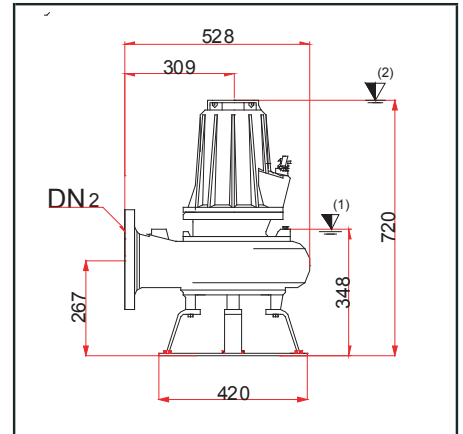
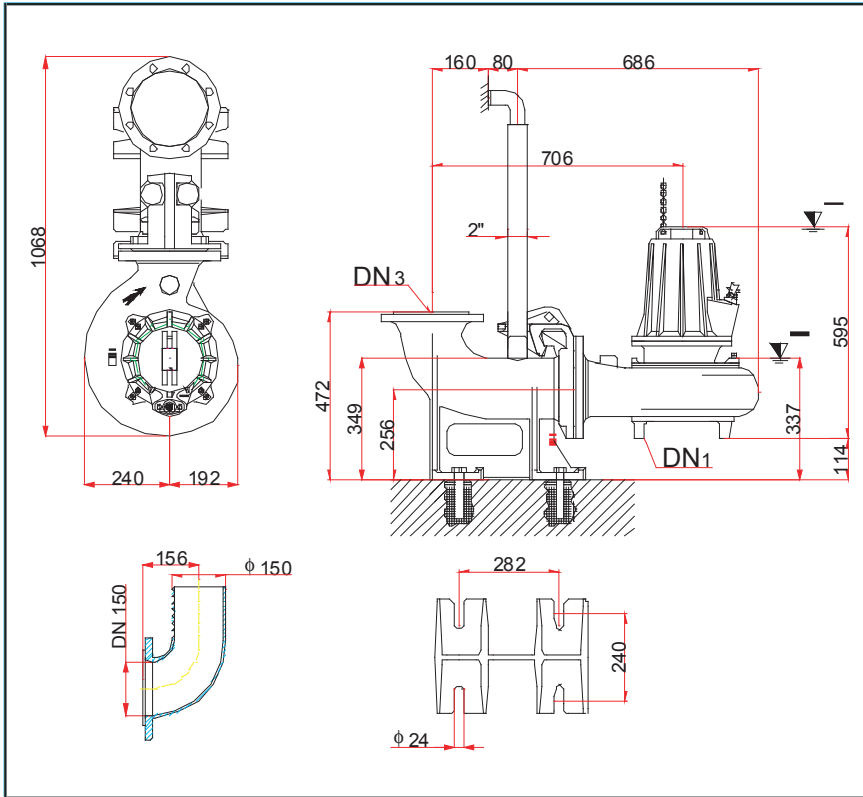

Dimensioni flange UNI
UNI flange dimensions

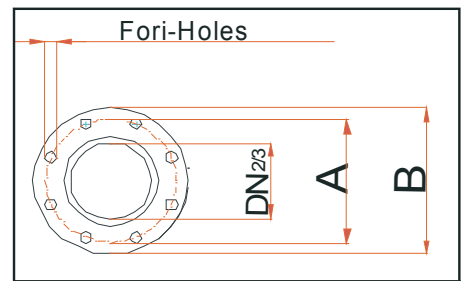

DIMENSIONI FLANGE UNI - UNI FLANGE DIMENSIONS

| TIPO - TYPE | DN 1 | DN 2/3 | A | B | Fori - Holes | | OPTIONAL | | | |
|--------------------|------|--------|-----|-----|--------------|------|-----------|-----------|----------------|--|
| | | | | | n° | φ mm | | | | |
| AT 150-4-173 C.258 | 150 | 150 | 240 | 285 | 8 | 22 | P7-DN 150 | B7-DN 150 | DN 150 - PN 16 | |

CARATTERISTICHE TECNICHE - TECHNICAL FEATURES

| TIPO - TYPE | CAVO - CABLE H07 - RNF | MT | Sonde termiche Thermal probes | si yes | | | | |
|--------------------|---------------------------|----|---|-----------|--------------------|--------------------|--------------------|--------------------|
| | | | Sonda di conduttività Conductivity probe | si yes | Superiore Upper | Inferiore Lower | Superiore Upper | Inferiore Lower |
| AT 150-4-173 C.258 | (1) 10x1,5 φ 20 Y-△ | 10 | | | AR30 | MG1/30/G6 | 6206 2Z | 3306 2Z |

NOTE - NOTES :

(1) Punto inferiore d'arresto nel caso di funzionamento automatico
Lowest shut-off point for automatic operation

(2) Sommergenza minima nel caso di funzionamento continuo
Minimum covering for continuous operation

AT 150/4/200 C. 260-263

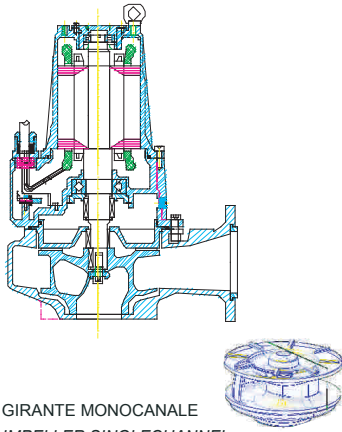

GIRANTE MONOCANALE
IMPELLER SINGLECHANNEL

| | |
|------------------|------|
| PASSAGGIO LIBERO | 80mm |
| FREE PASSAGE | 80mm |

| | |
|---------------|----------|
| ALBERO MOTORE | AISI 420 |
| MOTOR SHAFT | AISI 420 |

Curve secondo ISO 9906. Livello 2
Curves as per ISO 9906. Grade 2

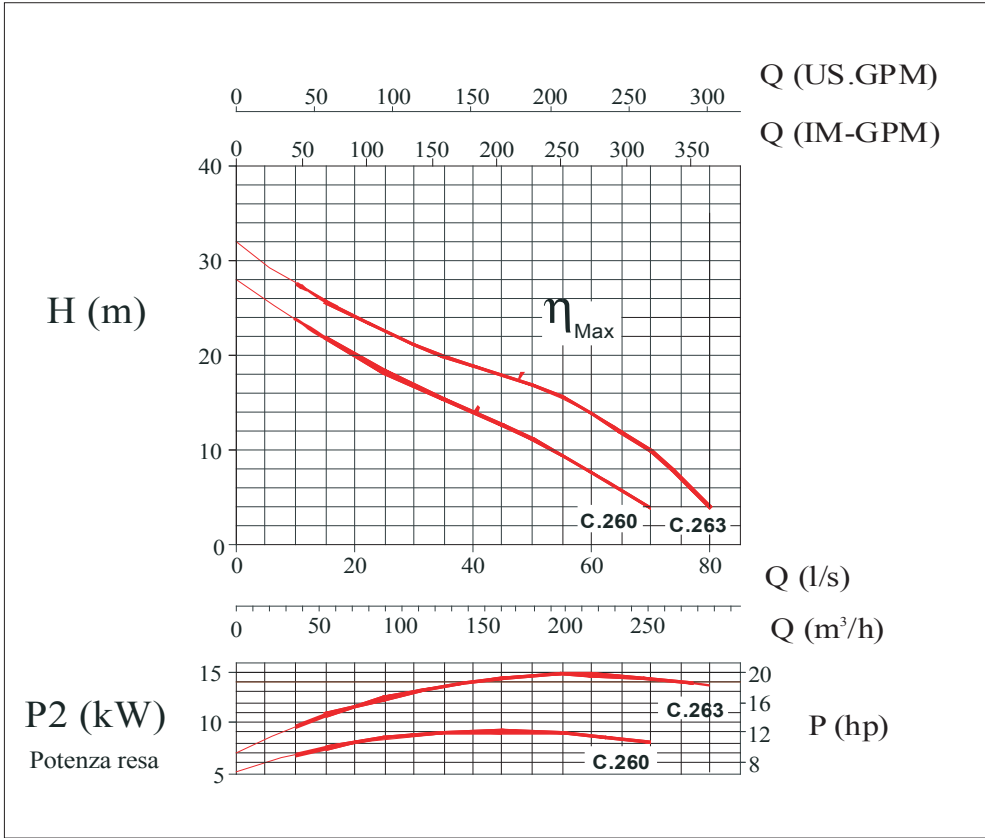

| Elettropompa Tipo | Prevalenza $\frac{Hm}{bar}$ | | | | | | | | | | | |
|---------------------|-----------------------------|-----|----|-----|-----|-----|-----|-----|-----|-----|-----|----|
| | 4 | 8 | 10 | 12 | 14 | 16 | 18 | 20 | 22 | 24 | 28 | |
| | 0,4 | 0,8 | 1 | 1,2 | 1,4 | 1,6 | 1,8 | 2,0 | 2,2 | 2,4 | 2,8 | |
| | Portata Q (l/s) | | | | | | | | | | | |
| AT 150/4/200 C. 260 | 70 | 60 | 55 | 45 | 40 | 35 | 25 | 20 | 15 | 10 | | |
| AT 150/4/200 C. 263 | 80 | 74 | 70 | 65 | 60 | 55 | 45 | 35 | 27 | 20 | 10 | 10 |

Dati tecnici / Specifications

| | Mandata | kW | | r.p.m | Poli | Ampere | Hz | Cos φ |
|---------------------|---------|------|-----|-------|------|------------|----|-------|
| | | P1 | P2 | 1/min | | Trifase 3~ | | |
| | | | | | | 400V | | |
| AT 150/4/200 C. 260 | DN2 150 | 12.1 | 9,3 | 1450 | 4 | 19.5 | 50 | 0.82 |
| AT 150/4/200 C. 263 | | 19.8 | 15 | 1450 | 4 | 30.5 | 50 | 0.83 |

Dimensioni di ingombro dell'imballo
Overall dimensions of packing

| TIPO | X | Y | Z | Kg |
|---------------------|-----|-----|-----|-----|
| AT 150/4/200 C. 260 | 600 | 850 | 500 | 226 |
| AT 150/4/200 C. 263 | 600 | 850 | 500 | 235 |

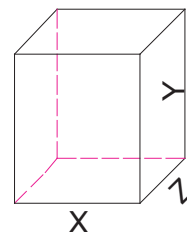

AT 150/4/200 C.260-263

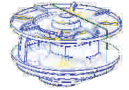

INSTALLAZIONE FISSA
STATIONARY INSTALLATION

INSTALLAZIONE MOBILE
MOBILE INSTALLATION

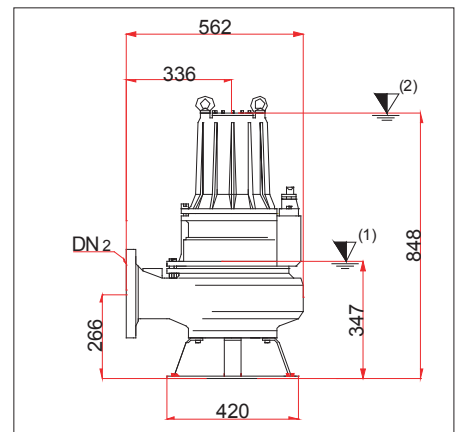
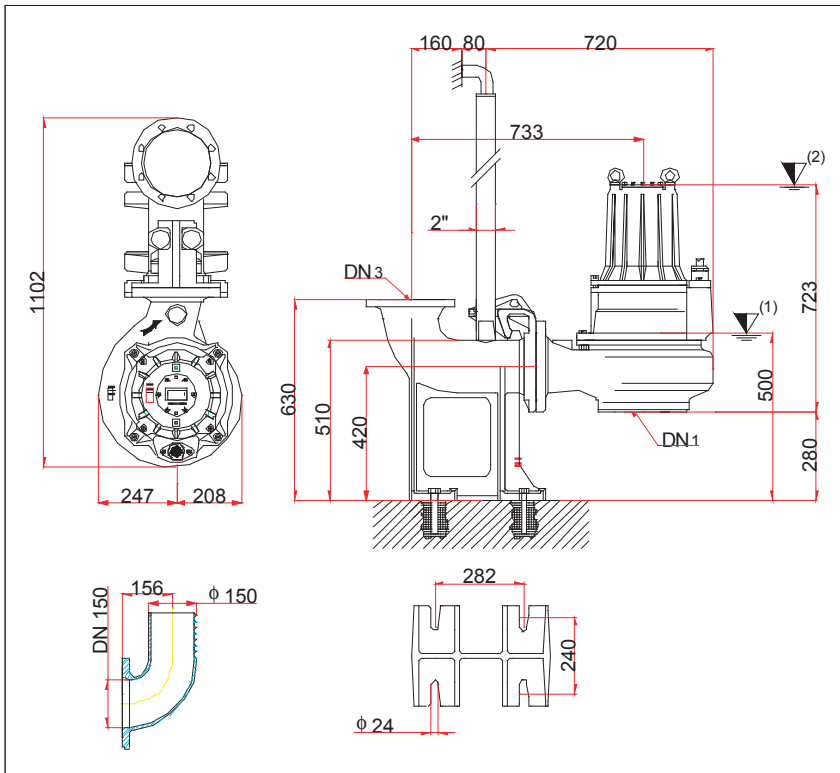

Dimensioni flange UNI
UNI flange dimensions

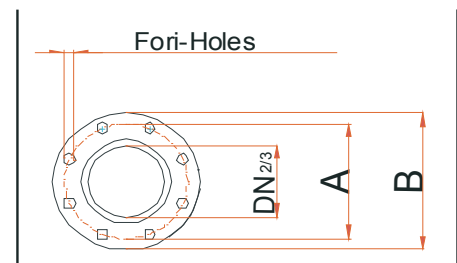

DIMENSIONI FLANGE UNI - UNI FLANGE DIMENSIONS

| TIPO - TYPE | DN 1 | DN 2/3 | A | B | Fori - Holes | | OPTIONAL | | | |
|--|------|--------|-----|-----|--------------|------|-----------|-----------|----------------|--|
| | | | | | n° | φ mm | | | | |
| AT 150-4-200 C.260 AT 150-4-200 C.263 | 150 | 150 | 240 | 285 | 8 | 22 | P7-DN 150 | B8-DN 150 | DN 150 - PN 16 | |

CARATTERISTICHE TECNICHE - TECHNICAL FEATURES

| TIPO - TYPE | CAVO - CABLE H07 - RNF | MT | Sonde termiche Thermal probes | | | | | |
|--|---------------------------|----|----------------------------------|--|--------------------|--------------------|--------------------|--------------------|
| | | | si yes | | Superiore Upper | Inferiore Lower | Superiore Upper | Inferiore Lower |
| AT 150-4-200 C.260 AT 150-4-200 C.263 | (1) 10x2,5 φ 23 Y-△ | 10 | si yes | | Superiore Upper | Inferiore Lower | Superiore Upper | Inferiore Lower |
| | | | | | MG1/55/G4 | MG1/40/G6 | NU 207ECJ3 | 6312 2RS1 |

NOTE - NOTES :



Punto inferiore d'arresto nel caso di funzionamento automatico
Lowest shut-off point for automatic operation



Sommergenza minima nel caso di funzionamento continuo
Minimum covering for continuous operation

AT 150/4/200 C. 264-265

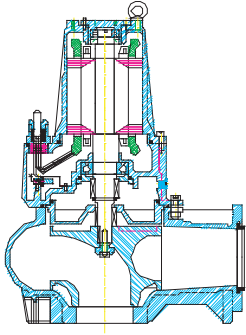

GIRANTE MONOCANALE
IMPELLER SINGLECHANNEL

| | |
|------------------|-------|
| PASSAGGIO LIBERO | 110mm |
| FREE PASSAGE | 110mm |

| | |
|---------------|----------|
| ALBERO MOTORE | AISI 420 |
| MOTOR SHAFT | AISI 420 |

Curve secondo ISO 9906. Livello 2
Curves as per ISO 9906. Grade 2

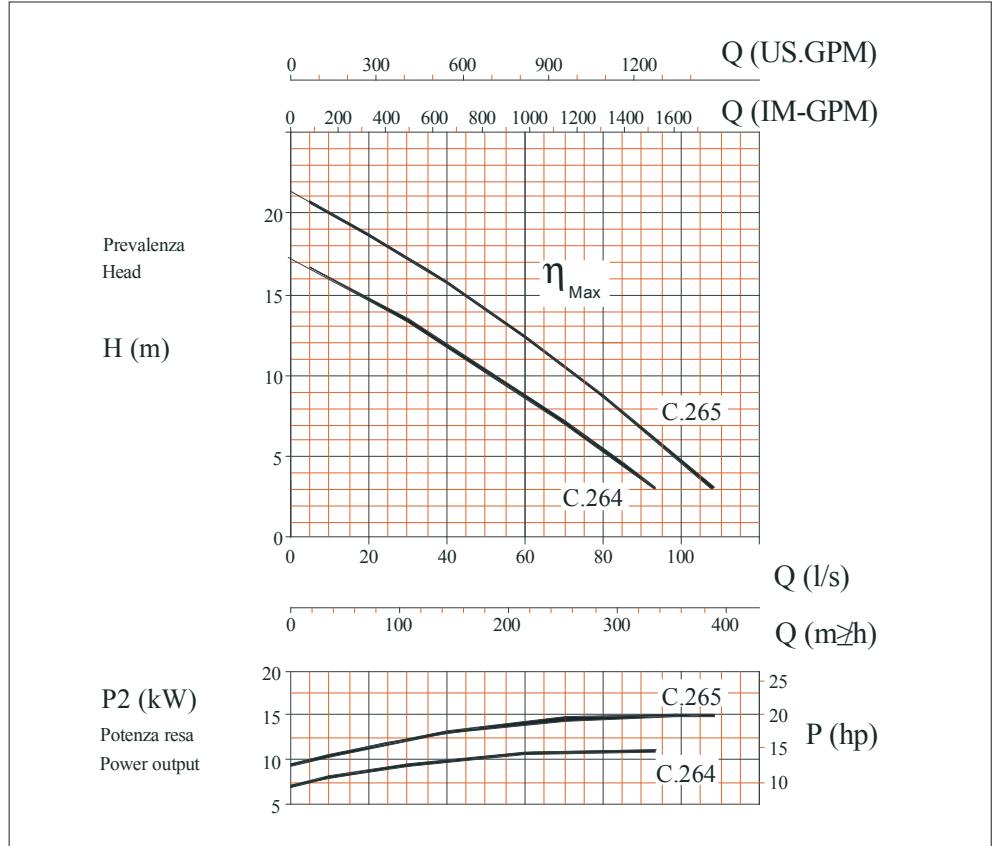

| Elettropompa Tipo Electric pump Type | Prevalenza - Head | | | | | | | | | | |
|---|--------------------|-----|-----|-----|----|-----|-----|-----|-----|----|-----|
| | Hm bar | | | | | | | | | | |
| | 2 | 4 | 6 | 8 | 10 | 12 | 14 | 16 | 18 | 20 | 22 |
| | Portata - Capacity | | | | | | | | | | |
| | Q (l/s) | | | | | | | | | | |
| | 0,2 | 0,4 | 0,6 | 0,8 | 1 | 1,2 | 1,4 | 1,6 | 1,8 | 2 | 2,2 |
| AT 150/4/200 C. 264 | | 87 | 76 | 65 | 52 | 39 | 25 | 10 | | | |
| AT 150/4/200 C. 265 | | 104 | 94 | 85 | 73 | 62 | 50 | 38 | 25 | 10 | |

Dati tecnici / Specifications

| | Mandata Delivery | kW | | r.p.m | Poles | Ampere | Hz | Cos φ |
|---------------------|---------------------|------|------|-------|-------|------------|----|-------|
| | | P1 | P2 | 1/min | | Trifase 3~ | | |
| | | | | | | 400V | | |
| AT 150/4/200 C. 264 | DN2 150 | 14,8 | 11 | 1450 | 4 | 21 | 50 | 0,86 |
| AT 150/4/200 C. 265 | | 19,8 | 14,7 | 1450 | 4 | 30 | 50 | 0,87 |

Dimensioni di ingombro dell'imballo
Overall dimensions of packing

| TIPO-TYPE | X | Y | Z | Kg |
|---------------------|-----|-----|-----|-----|
| AT 150/4/200 C. 264 | 550 | 860 | 645 | 260 |
| AT 150/4/200 C. 265 | 550 | 860 | 645 | 272 |

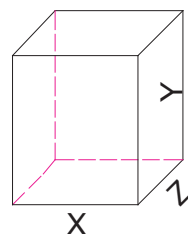

Dimensioni - Dimensions

AT 150/4/200 C.264-265

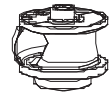

INSTALLAZIONE FISSA
STATIONARY INSTALLATION

INSTALLAZIONE MOBILE
MOBILE INSTALLATION

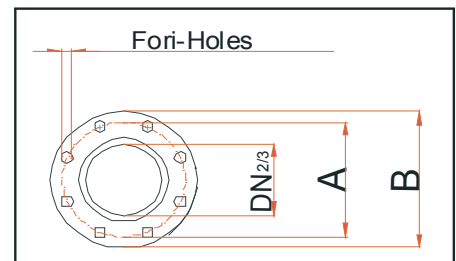
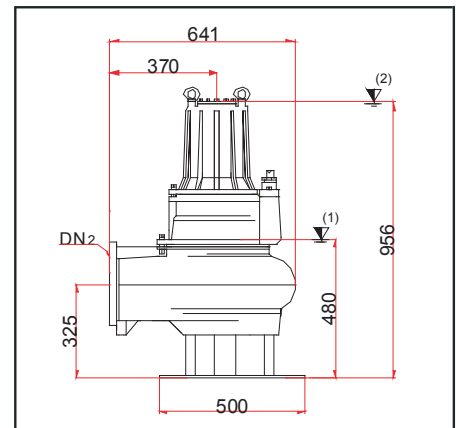
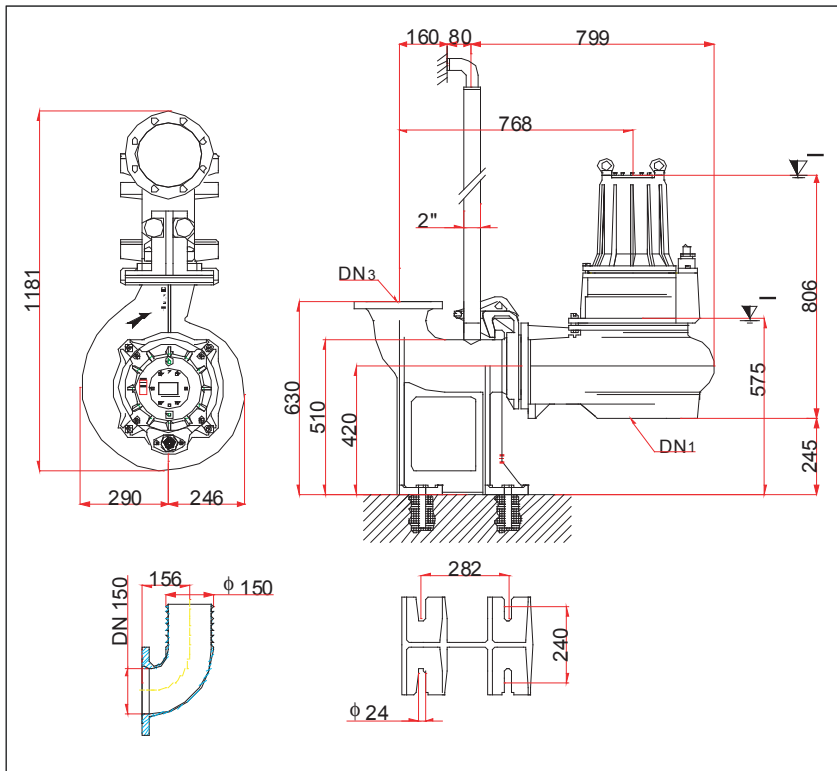

DIMENSIONI FLANGE UNI - UNI FLANGE DIMENSIONS

| TIPO - TYPE | DN ₁ | DN _{2/3} | A | B | Fori - Holes | | OPTIONAL | | | |
|--|-----------------|-------------------|-----|-----|--------------|------|-----------|-----------|----------------|--|
| | | | | | n° | φ mm | | | | |
| AT 150-4-200 C.264 AT 150-4-200 C.265 | 150 | 150 | 240 | 285 | 8 | 22 | P8-DN 150 | B8-DN 150 | DN 150 - PN 16 | |

CARATTERISTICHE TECNICHE - TECHNICAL FEATURES

| TIPO - TYPE | CAVO - CABLE H07 - RNF | MT | Sonde termiche Thermal probes | | | | | | | |
|--|---------------------------|----|---|--|--------------------|--------------------|--------------------|--------------------|-------------|-----------|
| | | | si yes | | Superiore Upper | Inferiore Lower | Superiore Upper | Inferiore Lower | | |
| AT 150-4-200 C.264 AT 150-4-200 C.265 | (1) 10x2,5 φ 23 Y-Δ | 10 | Sonda di conduttività Conductivity probe | | si yes | | | | | |
| | | | | | | | MG1/55/G4 | MG1/40/G6 | NU 207ECJC3 | 6312 2RS1 |

NOTE - NOTES :



Punto inferiore d'arresto nel caso di funzionamento automatico
Lowest shut-off point for automatic operation



Sommergenza minima nel caso di funzionamento continuo
Minimum covering for continuous operation

AT 150/4/240 C. 275-280

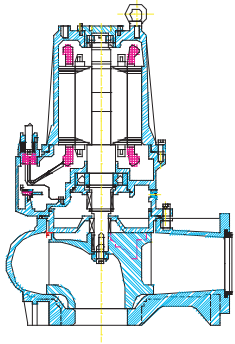

GIRANTE MONOCANALE
IMPELLER SINGLECHANNEL

| | |
|------------------|-------|
| PASSAGGIO LIBERO | 120mm |
| FREE PASSAGE | 120mm |

| | |
|---------------|----------|
| ALBERO MOTORE | AISI 420 |
| MOTOR SHAFT | AISI 420 |

Curve secondo ISO 9906. Livello 2
Curves as per ISO 9906. Grade 2

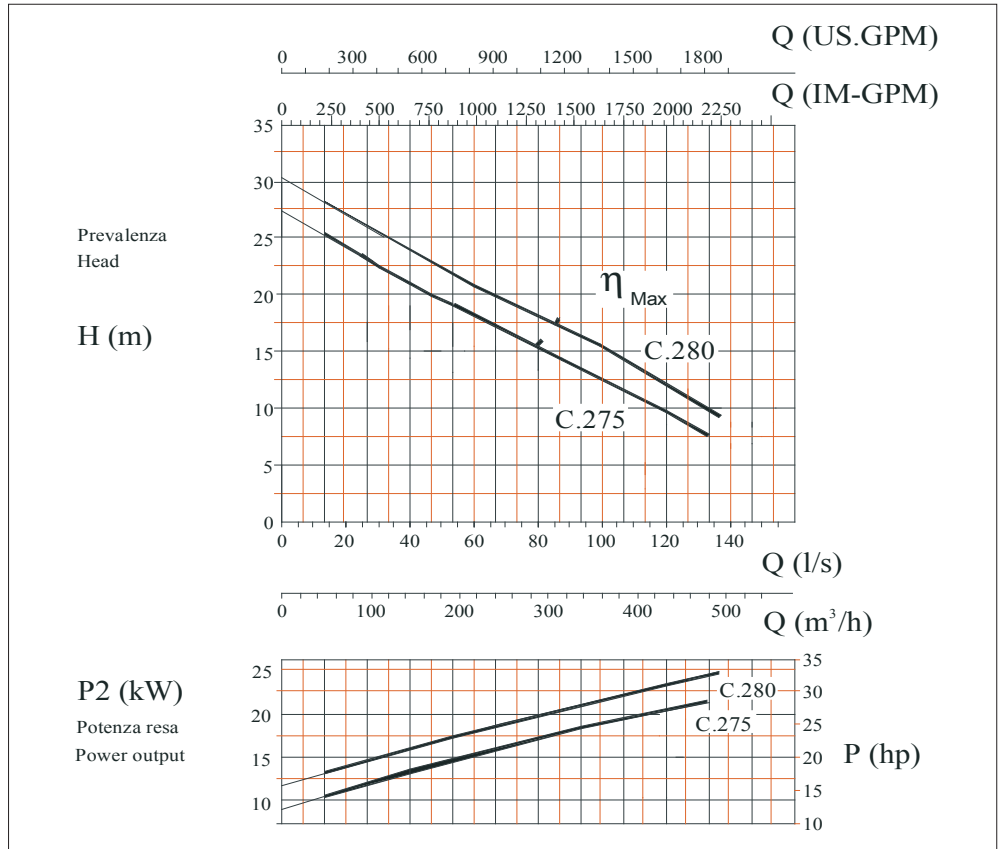

| Elettropompa Tipo Electric pump Type | Prevalenza - Head | | | | | | | | | | Hm | | | |
|---|--------------------|-----|------|-----|------|----|------|-----|------|----|---------|--|--|--|
| | | | | | | | | | | | bar | | | |
| | 7,5 | 10 | 12,5 | 15 | 17,5 | 20 | 22,5 | 25 | 27,5 | 30 | 32,5 | | | |
| | 0,75 | 1 | 1,25 | 1,5 | 1,75 | 2 | 2,25 | 2,5 | 2,75 | 3 | 3,25 | | | |
| | Portata - Capacity | | | | | | | | | | Q (l/s) | | | |
| AT 150/4/240 C. 275 | 134 | 118 | 100 | 85 | 65 | 45 | 30 | 18 | | | | | | |
| AT 150/4/240 C. 280 | | 136 | 117 | 105 | 85 | 66 | 46 | 34 | 20 | 10 | | | | |

Dati tecnici / Specifications

| | Mandata Delivery | kW | | r.p.m | Poles | Ampere | Hz | Cos φ | |
|---------------------|---------------------|------|----|-------|-------|--------------------|----|-------|--|
| | | P1 | P2 | 1/min | | Trifase 3~ 400V | | | |
| AT 150/4/240 C. 275 | DN2 150 | 29,7 | 22 | 1450 | 4 | 43 | 50 | 0,84 | |
| AT 150/4/240 C. 280 | | 33,7 | 25 | 1450 | 4 | 50 | 50 | 0,84 | |

Dimensioni di ingombro dell'imballo
Overall dimensions of packing

| TIPO-TYPE | X | Y | Z | Kg |
|---------------------|-----|-----|-----|-----|
| AT 150/4/240 C. 275 | 550 | 860 | 645 | 308 |
| AT 150/4/240 C. 280 | 550 | 860 | 645 | 320 |

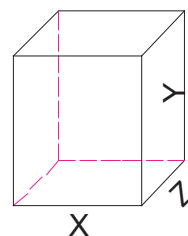

Dimensioni - Dimensions

AT 150/4/240 C.275-280

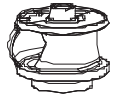

INSTALLAZIONE FISSA
STATIONARY INSTALLATION

INSTALLAZIONE MOBILE
MOBILE INSTALLATION

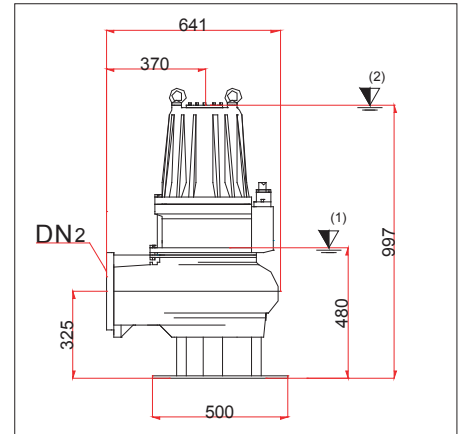
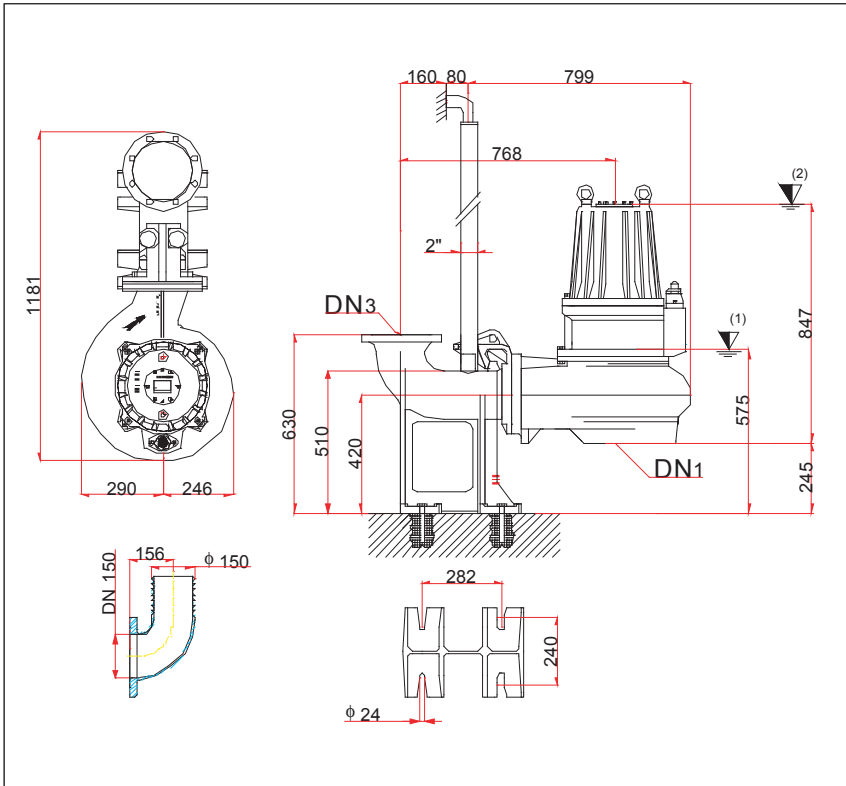

Dimensioni flange UNI
UNI flange dimensions

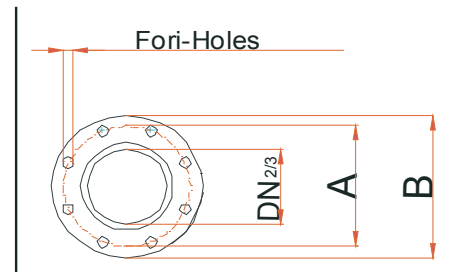

DIMENSIONI FLANGE UNI - UNI FLANGE DIMENSIONS

| TIPO - TYPE | DN 1 | DN 2/3 | A | B | Fori - Holes | | OPTIONAL | | | |
|--|------|--------|-----|-----|--------------|------|-----------|-----------|----------------|--|
| | | | | | n° | φ mm | | | | |
| AT 150-4-240 C.275 AT 150-4-240 C.280 | 150 | 150 | 240 | 285 | 8 | 22 | P8-DN 150 | B8-DN 150 | DN 150 - PN 16 | |

CARATTERISTICHE TECNICHE - TECHNICAL FEATURES

| TIPO - TYPE | CAVO - CABLE H07 - RNF | MT | Sonde termiche Thermal probes | si yes | | | | |
|--|----------------------------|----|---|-----------|--------------------|--------------------|--------------------|--------------------|
| | | | Sonda di conduttività Conductivity probe | si yes | Superiore Upper | Inferiore Lower | Superiore Upper | Inferiore Lower |
| AT 150-4-240 C.275 AT 150-4-240 C.280 | (1) 7x4+3x1 φ 20,5 Y- Δ | 10 | | | MG1/55/G4 | MG1/40/G6 | NU 207EGJC3 | 6314 2RS1 |

NOTE - NOTES :

(1) Punto inferiore d'arresto nel caso di funzionamento automatico
Lowest shut-off point for automatic operation

(2) Sommergenza minima nel caso di funzionamento continuo
Minimum covering for continuous operation

AT 150/4/340 C. 285-290-295

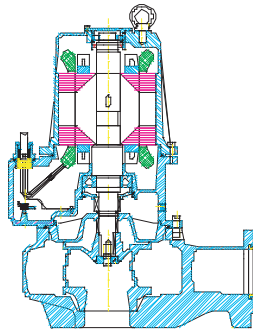

GIRANTE MONOCANALE
IMPELLER SINGLECHANNEL

PASSAGGIO LIBERO 120mm
FREE PASSAGE 120mm

| | |
|--------|-------|
| C. 285 | 110mm |
| C. 290 | 120mm |
| C. 295 | 130mm |

ALBERO MOTORE AISI 420
MOTOR SHAFT AISI 420

Curve secondo ISO 9906. Livello 2
Curves as per ISO 9906. Grade 2

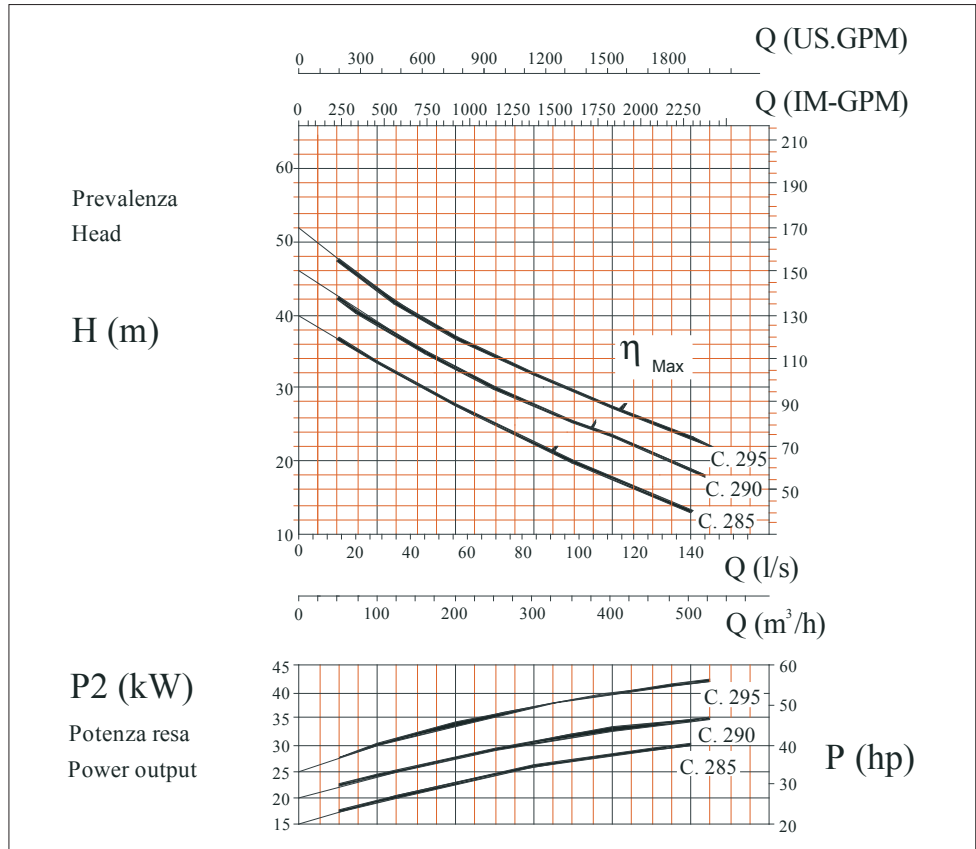

| Elettropompa Tipo Electric pump Type | Prevalenza - Head | | | | | | | | | | Hm bar | | |
|---|-------------------|-----|-----|-----|------|----|------|-----|-----|-----|-----------|---------|--|
| | 10 | 14 | 18 | 22 | 26 | 30 | 34 | 38 | 42 | 46 | 48 | | |
| | 1 | 1,4 | 1,8 | 2,2 | 2,6 | 3 | 3,4 | 3,8 | 4,2 | 4,6 | 4,8 | | |
| Portata - Capacity | | | | | | | | | | | | Q (l/s) | |
| AT 150/4/340 C. 285 | | 130 | 107 | 85 | 62 | 42 | 25,5 | 15 | | | | | |
| AT 150/4/340 C. 290 | | | 145 | 119 | 92,5 | 67 | 48 | 33 | 20 | | | | |
| AT 150/4/340 C. 295 | | | | 147 | 120 | 96 | 70 | 48 | 33 | 19 | 14 | | |

Dati tecnici / Specifications

| | Mandata Delivery | kW | | r.p.m | Poles | Ampere | Hz | Cos φ |
|---------------------|---------------------|------|------|-------|-------|------------|----|-------|
| | | P1 | P2 | 1/min | | Trifase 3~ | | |
| | | | | | | 400V | | |
| AT 150/4/340 C. 285 | DN2 150 | 39,8 | 29,5 | 1450 | 4 | 56 | 50 | 0,82 |
| AT 150/4/340 C. 290 | | 46,7 | 35 | 1450 | 4 | 68 | 50 | 0,82 |
| AT 150/4/340 C. 295 | | 58 | 43 | 1450 | 4 | 81 | 50 | 0,82 |

Dimensioni di ingombro dell'imballo
Overall dimensions of packing

| TIPO-TYPE | X | Y | Z | Kg |
|---------------------|-----|------|-----|-----|
| AT 150/4/340 C. 285 | 604 | 1038 | 800 | 545 |
| AT 150/4/340 C. 290 | 604 | 1038 | 800 | 585 |
| AT 150/4/340 C. 295 | 604 | 1038 | 800 | 590 |

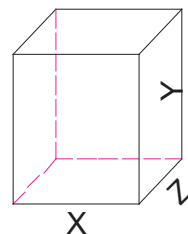

Dimensioni - Dimensions

AT 150/4/340 C.285-290-295

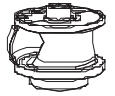

INSTALLAZIONE FISSA
STATIONARY INSTALLATION

INSTALLAZIONE MOBILE
MOBILE INSTALLATION

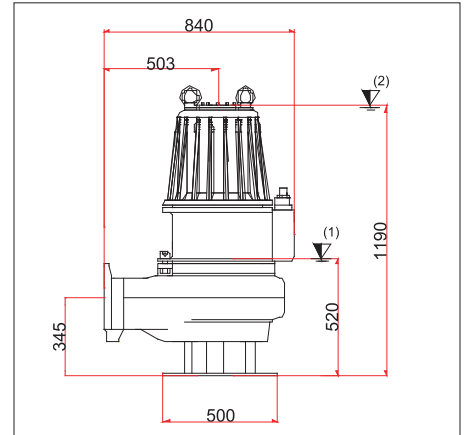
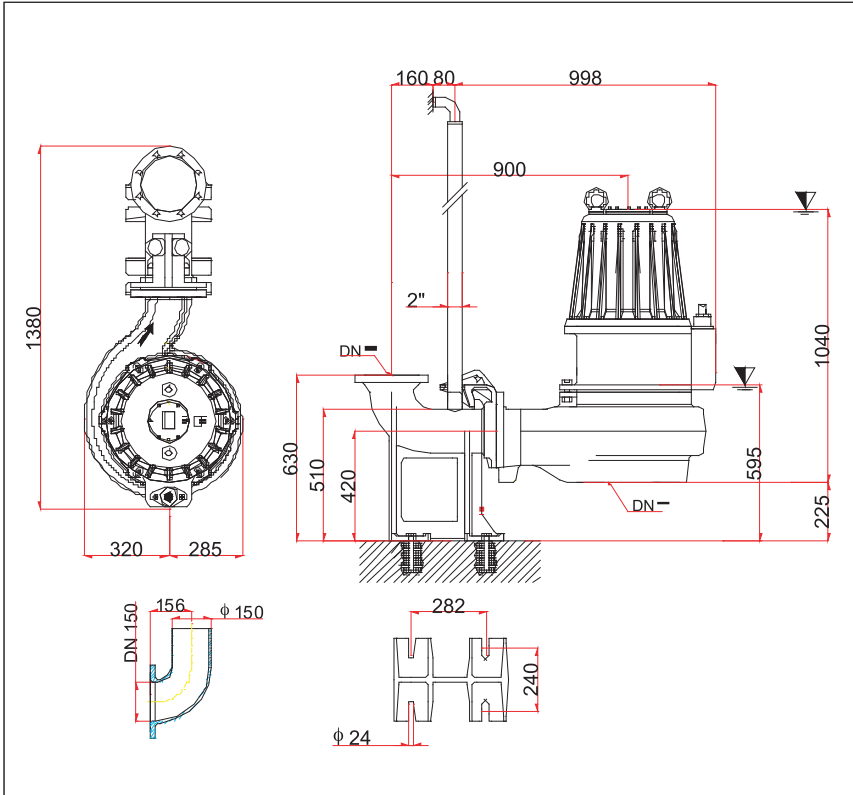

Dimensioni flange UNI
UNI flange dimensions

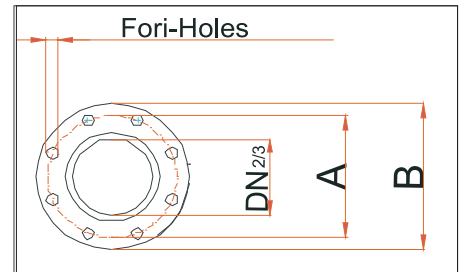

DIMENSIONI FLANGE UNI - UNI FLANGE DIMENSIONS

| TIPO - TYPE | DN 1 | DN 2/3 | A | B | Fori - Holes | | OPTIONAL | | | |
|--|------|--------|-----|-----|--------------|------|-----------|-----------|----------------|--|
| | | | | | n° | φ mm | | | | |
| AT 150/4/340 C.285 AT 150/4/340 C.290 AT 150/4/340 C.295 | 150 | 150 | 240 | 285 | 8 | 22 | P8-DN 150 | B8-DN 150 | DN 150 - PN 16 | |

CARATTERISTICHE TECNICHE - TECHNICAL FEATURES

| TIPO - TYPE | CAVO - CABLE H07 - RNF | MT | Sonde termiche Thermal probes | si yes | | | | |
|--|---------------------------|----|---|-----------|--------------------|--------------------|--------------------|--------------------|
| | | | Sonda di conduttività Conductivity probe | si yes | Superiore Upper | Inferiore Lower | Superiore Upper | Inferiore Lower |
| AT 150/4/340 C.285 AT 150/4/340 C.290 AT 150/4/340 C.295 | (1) 7x10+5x1 φ 29 Y-Δ | 10 | | | MG1/65/G6 | MG1/55/G4 | NU 211 EC | 6316 2RS1 |

NOTE - NOTES :

Punto inferiore d'arresto nel caso di funzionamento automatico
Lowest shut-off point for automatic operation

Sommergenza minima nel caso di funzionamento continuo
Minimum covering for continuous operation



| Tipo Type | Capacità [lt] Capacity [lt] | Piede di Acc. Automatic C. Foot | Dimensioni Dimensions | | | Kgs |
|--------------------|--------------------------------|------------------------------------|--------------------------|------|---------|-----|
| | | | Ø | H | C x D | |
| PAC 120 | 120 | - | 500 | 750 | Ø 300 | 8 |
| PAC 120/PA | 120 | 1 x 1" 1/2 | 500 | 750 | Ø 300 | 15 |
| PAC 400/PA | 400 | 1 x 2" | 800 | 880 | Ø 600 | 32 |
| PAC400 ECO/D-PA | 400 | 2 x 2" | 800 | 880 | Ø 600 | 39 |
| PAC 800/PA | 800 | 1 x 2" | 800 | 1200 | Ø 600 | 42 |
| PAC 800/D-PA | 800 | 2 x 2" | 800 | 1200 | Ø 600 | 54 |
| PAC 1500/D-PA | 1200 | 2 x 2" | 1250 | 1250 | 530x530 | 85 |

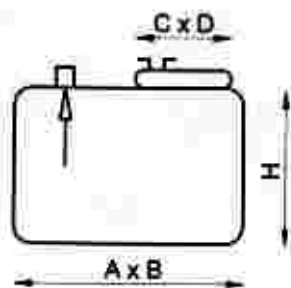

| Tipo Type | Capacità [lt] Capacity [lt] | Piede di Acc. Automatic C. Foot | Dimensioni Dimensions | | | Kgs |
|--------------|--------------------------------|------------------------------------|--------------------------|-----|---------|-----|
| | | | A x B | H | C x D | |
| TAVER 50 | 48 | - | 310x480 | 440 | Ø 200 | 6 |
| TAVER 63 | 63 | - | 340x530 | 520 | Ø 200 | 5 |
| PAC 100 | 100 | - | 405x605 | 620 | Ø 200 | 5 |
| PAC 175 | 175 | - | 460x760 | 710 | 350x350 | 13 |
| PAC 175/PA | 175 | 1 x 2" | 460x760 | 710 | 350x350 | 18 |
| PAC 330/PA | 330 | 1 x 2" | 760x900 | 890 | Ø 320 | 21 |
| PAC 500/D-PA | 550 | 2 x 2" | 850x1115 | 836 | 310x556 | 55 |

Complete di:

Mandata Filettata 2" (1" 1/4 TAVER 50-63)
 Raccordo di entrata Ø 110 mm a bicchiere
 Raccordo ventilazione Ø 50 mm a bicchiere
 Uscita cavo alimentazione pompa
 Uscita cavo galleggiante di allarme
 Base in Moplen (dove prevista)
 Piede di accompagnamento (dove previsto)

Complete of:

Threaded delivery 2" (1" 1/4 TAVER 50-63)
 Entry funnel unio Ø 110 mm
 Ventilation funnel union Ø 50 mm
 Net cable exit
 Level switch cable exit
 Foot Support in Moplen (where required)
 Automatic coupling foot (where required)

Disponibili su richiesta stazioni di pompaggio fino a 5900 lt.
 Available on request pumping stations up to 5900 lt.

**ACCESSORI PER L'INSTALLAZIONE
INSTALLATION ACCESSORIES**
INSTALLAZIONE MOBILE – MOBILE INSTALLATION

| | | |
|---------------------------------------|---|--|
| | BASE DI APPOGGIO - FOOT SUPPORT | |
| | P1 | Base di appoggio GT 32/2/125 |
| | P2 | Base di appoggio GT 65/2/152 |
| | P3 | Base di appoggio GT 65/2/173 |
| | P4 | Base di appoggio AT-VT-HT 65 |
| | P5 | Base di appoggio AT-VT 80 |
| | P6 | Base di appoggio AT-VT 100 |
| | P7 | Base di appoggio AT-VT 150 |
| | P8 | Base di appoggio AT-VT 150* |
| * Innesto a Baionetta – Bayonet Joint | | |
| | FLANGIA FILETTATA A COLLARE PN 16 THREADED COUPLING FLANGE WITH THREAD PN 16 | |
| | DN 65 | Flangia Quadra |
| | DN 80 | Flangia Cilindrica |
| | DN 100 | Flangia Cilindrica |
| | DN 150 | Flangia Cilindrica |
| | CURVA FLANGIATA PORTAGOMMA FLANGED HOSE CONNECTION | |
| | DN 65 | Curva 90° con flangia Quadra <input type="checkbox"/> |
| | DN 80 | Curva 90° con flangia Cilindrica <input type="radio"/> |
| | DN 100 | Curva 90° con flangia Cilindrica <input type="radio"/> |
| | DN 150 | Curva 90° con flangia Cilindrica <input type="radio"/> |

INSTALLAZIONE FISSA – STATIONARY INSTALLATION

| | | |
|--|--|-----------------------------------|
| | PIEDE PER ACCOPPIAMENTO RAPIDO FILETTATO AUTOMATIC COUPLING FOOT / THREADED | |
| | B1 | Installazione Fissa G - 1" 1/4 |
| | B2 | Installazione Fissa G - 1" 1/2 |
| | B3 | Installazione Fissa G - 2" |
| | PIEDE PER ACCOPPIAMENTO RAPIDO TIPO B AUTOMATIC COUPLING FOOT TYPE B | |
| | B4 | Piede Accoppiamento Rapido DN 65 |
| | B5 | Piede Accoppiamento Rapido DN 80 |
| | B6 | Piede Accoppiamento Rapido DN 100 |
| | B7 | Piede Accoppiamento Rapido DN 150 |
| | B8 | Piede Accoppiamento Rapido DN 150 |

Accessori per l'installazione - Installation Accessories

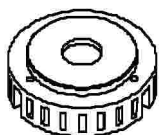

CESTELLO - STRAINER

| | | | |
|----|------------------|------|----|
| C1 | Cestello-Griglia | AM/T | 32 |
| C2 | Cestello-Griglia | AM/T | 40 |
| C3 | Cestello-Griglia | AM/T | 50 |

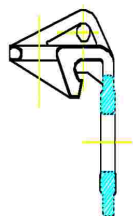

**SOSTEGNO DI UNIONE PER PIEDE D'ACCOPPIAMENTO TIPO B
COUPLING SUPPORT PN 16 FOR AUTOMATIC COUPLING FOOT TYPE B**

| | | | | |
|------------------------------|------|----|-----|--------------------------|
| Sostegno di Unione per Piede | B4 | DN | 65 | <input type="checkbox"/> |
| Sostegno di Unione per Piede | B5 | DN | 80 | O |
| Sostegno di Unione per Piede | B6 | DN | 100 | O |
| Sostegno di Unione per Piede | B7-8 | DN | 150 | O |

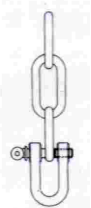

**CATENA ZINCATA A CALDO
ZINC PLATED CHAIN**

| Modello -Type | Ø mm. | Portata Kg.- Max Load Kg. |
|---------------|-------|---------------------------|
| 21 | 5 | 160 |
| 26 | 7.5 | 300 |
| 36 | 12 | 650 |

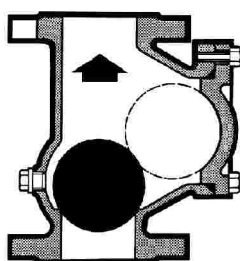

**VALVOLA DI RITEGNO A PALLA
NON RETURN BALL VALVE**

| | |
|----------------------------|------------|
| Valvola di Ritegno a Palla | G - 1" 1/4 |
| Valvola di Ritegno a Palla | G - 1" 1/2 |
| Valvola di Ritegno a Palla | G - 2" |
| Valvola di Ritegno a Palla | Dn 65 * |
| Valvola di Ritegno a Palla | Dn 80 * |
| Valvola di Ritegno a Palla | Dn 100 * |
| Valvola di Ritegno a Palla | Dn 150 * |

* Esclusa controflangia - Counter Flange Excluded

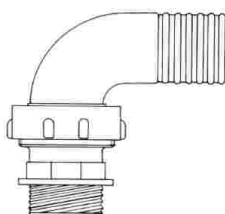



**RACCORDO PORTAGOMMA CURVO 90°
90° PIPE ELBOWS**

| | | |
|--------------|--------|-------------------|
| Raccordo 90° | 1" 1/4 | IN 3 PEZZI PVC |
| Raccordo 90° | 1" 1/2 | IN 3 PEZZI PVC |
| Raccordo 90° | 2" | IN 3 PEZZI PVC |
| Raccordo 90° | 1" 1/4 | IN 3 PEZZI OTTONE |
| Raccordo 90° | 1" 1/2 | IN 3 PEZZI OTTONE |
| Raccordo 90° | 2" | IN 3 PEZZI OTTONE |

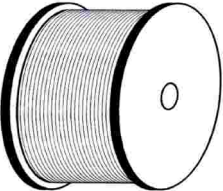

**TENUTA MECCANICA
MECHANICAL SEAL**

| | | |
|------|---------------------------|---------------------------|
| Ø 12 | Carburo di Silicio +Viton | - Silicon/Carbide + Viton |
| Ø 14 | Carburo di Silicio +Viton | - Silicon/Carbide + Viton |
| Ø 20 | Carburo di Silicio +Viton | - Silicon/Carbide + Viton |
| Ø 25 | Carburo di Silicio +Viton | - Silicon/Carbide + Viton |
| Ø 30 | Carburo di Silicio +Viton | - Silicon/Carbide + Viton |
| Ø 40 | Carburo di Silicio +Viton | - Silicon/Carbide + Viton |
| Ø 55 | Carburo di Silicio +Viton | - Silicon/Carbide + Viton |
| Ø 65 | Carburo di Silicio +Viton | - Silicon/Carbide + Viton |

| | | |
|---|--|-----------------------------|
|  | CAVO ELETTRICO ELECTRIC CABLE | H07RNF OIL RESISTANT |
| | CAVO 3x1 mm2 | Ø 9 |
| | CAVO 4x1 mm2 | Ø 10 |
| | CAVO 4x1.5 mm2 | Ø 11.5 |
| | CAVO 7x1.5 mm2 | Ø 15 |
| | CAVO 7x2.5 mm2 | Ø 18 |
| | CAVO 10x1.5 mm2 | Ø 20 |
| | CAVO 10x2.5 mm2 | Ø 23 |
| | CAVO 7x4 + 3x1 mm2 | Ø 20.5 |
| CAVO 7x10 + 5x1 mm2 | Ø 29 | |
|  | GALLEGGIANTE FLOAT SWITCH | H07RNF OIL RESISTANT |
| | G 05 con 0.5 Mt. | |
| | G 5 con 5 Mt. | |
| | G 10 con 10 Mt. | |
| | G 15 con 15 Mt. | |
| | G 20 con 20 Mt. | |
| | G 30 con 30 Mt. | |
| | CPGG25 Contrappeso in Ghisa GG 22 | |
| GG 10 Tipo pesante a bulbo con 10 Mt Cavo | | |

INSTALLAZIONE MOBILE

Per un impiego mobile e veloce anche in casi di emergenza o assistenza. L'elettropompa può funzionare completamente o parzialmente sommersa, vedi sommergenza

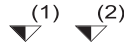

MOBILE INSTALLATION

For mobile operations in case of emergency or assistance. The electric motor pump operate completely or partially submerged



INSTALLAZIONE FISSA

L'installazione fissa sommersa mediante il sistema di accoppiamento con due tubi guida permette un accoppiamento automatico dell'elettropompa al piede e quindi alla condotta di scarico, garantendo una tenuta perfetta, grazie al peso dell'elettropompa. L'elettropompa può essere facilmente estratta per il controllo e la manutenzione senza la necessità di entrare nel pozzetto. L'elettropompa può funzionare completamente o parzialmente sommersa, vedi sommergenza

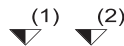

STATIONARY INSTALLATION

The submerged stationary installations with our two guide pipes coupling systems allow automatic coupling of the electric motor pump to the discharge conduct, perfect sealing is guaranteed thanks to the pump's weight. The pump can easily be removed for checks and/or maintenance works, without the necessity to enter into the pumpwork. The electric motor pumps operate completely or partially submerged



SISTEMA DI INSTALLAZIONE
(Esempio di installazione)

STATIONARY INSTALLATION
(Example on Installation)

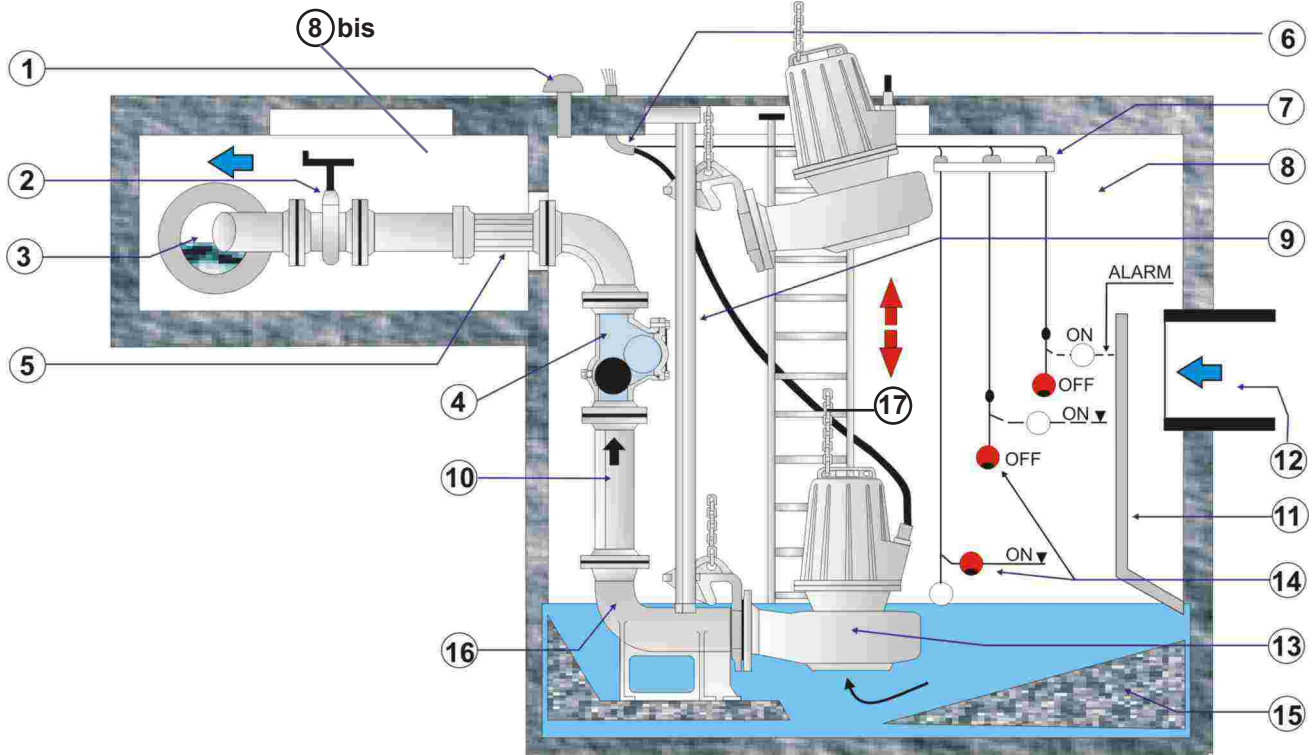

- 1. Aeration pipe
- 2. Gate valve
- 3. Drainage manifold
- 4. Ball valve
- 5. Joint
- 6. Cable protection tube
- 7. Level control bracket
- 8. Lifting well
- 8bis. Ventilation chamber
- 9. Guiding pipe
- 10. Delivery piping
- 11. Damping chamber partition
- 12. Sewage inlet pipe
- 13. Electropump
- 14. Automatic level controls
- 15. Concrete cast
- 16. Quick connect bedplate
- 17. Chain

- 1. Tubo di areazione
- 2. Saracinesca
- 3. Collettore di scarico
- 4. Valvola a palla.
- 5. Giunto
- 6. Tubo protezione cavi
- 7. Staffa regolatori di livello
- 8. Pozzetto di sollevamento
- 8bis. Camera di ventilazione
- 9. Tubo di guida
- 10. Tubazione di mandata
- 11. Setto camera di smorzamento
- 12. Tubo ingresso liquami
- 13. Elettropompa
- 14. Regolatori automatici di livello
- 15. Gettata di cemento
- 16. Basamento per accoppiamento rapido
- 17. Catena

Perdite di carico nelle curve, saracinesche e valvole
Pressure drop in curves, gates and valves

| Velocità dell'acqua in m/s water speed in m/s | Curve ad angolo vivo Alive angle curves | | | | | Curve normali Normal curves | | | | | Saracinesche normali normal gates | Valvole di fondo Foot valves | Valvole di ritegno not return valves | Perdite di energia all'uscita dei tubi di scarico V ² ·2g output hydraulic loss of the discharge tubes |
|--|--|-------|-------|-------|-------|--------------------------------|-------------------|-------------------|-----------------|-------------------|--------------------------------------|---------------------------------|---|--|
| | | | | | | | | | | | | | | |
| | a=30° | a=40° | a=60° | a=80° | a=90° | $\frac{d}{R}=0,4$ | $\frac{d}{R}=0,6$ | $\frac{d}{R}=0,8$ | $\frac{d}{R}=1$ | $\frac{d}{R}=1,5$ | | | | |
| 0,10 | 0,03 | 0,04 | 0,05 | 0,07 | 0,08 | 0,07 | 0,08 | 0,01 | 0,0155 | 0,027 | 0,03 | 30 | 30 | 0,05 |
| 0,15 | 0,06 | 0,73 | 0,1 | 0,14 | 0,17 | 0,016 | 0,019 | 0,024 | 0,033 | 0,06 | 0,033 | 31 | 31 | 0,12 |
| 0,2 | 0,11 | 0,13 | 0,18 | 0,26 | 0,31 | 0,028 | 0,033 | 0,04 | 0,058 | 0,11 | 0,58 | 31 | 31 | 0,21 |
| 0,25 | 0,17 | 0,21 | 0,28 | 0,4 | 0,48 | 0,044 | 0,052 | 0,63 | 0,091 | 0,17 | 0,09 | 31 | 31 | 0,32 |
| 0,3 | 0,25 | 0,3 | 0,41 | 0,6 | 0,7 | 0,063 | 0,074 | 0,09 | 0,13 | 0,25 | 0,13 | 31 | 31 | 0,46 |
| 0,35 | 0,33 | 0,4 | 0,54 | 0,8 | 0,93 | 0,085 | 0,10 | 0,12 | 0,18 | 0,33 | 0,18 | 31 | 31 | 0,62 |
| 0,4 | 0,43 | 0,52 | 0,71 | 1,0 | 1,2 | 0,11 | 0,13 | 0,16 | 0,23 | 0,43 | 0,23 | 32 | 31 | 0,82 |
| 0,5 | 0,67 | 0,81 | 1,1 | 1,6 | 1,9 | 0,18 | 0,21 | 0,26 | 0,37 | 0,67 | 0,37 | 33 | 32 | 1,27 |
| 0,6 | 0,97 | 1,2 | 1,6 | 2,3 | 2,8 | 0,25 | 0,29 | 0,36 | 0,52 | 0,97 | 0,52 | 34 | 32 | 1,84 |
| 0,7 | 1,35 | 1,65 | 2,2 | 3,2 | 3,9 | 0,34 | 0,40 | 0,48 | 0,70 | 1,35 | 0,7 | 35 | 32 | 2,5 |
| 0,8 | 1,7 | 2,1 | 2,8 | 4,0 | 4,8 | 0,45 | 0,53 | 0,64 | 0,93 | 1,7 | 0,95 | 36 | 33 | 3,3 |
| 0,9 | 2,2 | 2,7 | 6 | 5,2 | 6,2 | 0,57 | 0,67 | 0,82 | 1,18 | 2,2 | 1,2 | 37 | 34 | 4,2 |
| 1,0 | 2,7 | 3,3 | 4,5 | 6,4 | 7,6 | 0,7 | 0,82 | 1,0 | 1,45 | 2,7 | 1,45 | 38 | 35 | 5,1 |
| 1,5 | 6,0 | 7,3 | 10,0 | 14,0 | 17,0 | 1,6 | 1,9 | 2,3 | 3,3 | 6,0 | 3,3 | 47 | 40 | 11,5 |
| 2,0 | 11,0 | 14,0 | 18,0 | 26,0 | 31,0 | 2,8 | 3,3 | 4,0 | 5,8 | 11,0 | 5,8 | 61 | 48 | 20,4 |
| 2,5 | 17,0 | 21,0 | 28,0 | 40,0 | 48,0 | 4,4 | 5,2 | 6,3 | 9,1 | 17,0 | 9,1 | 78 | 58 | 32,0 |
| 3,0 | 25,0 | 30,0 | 41,0 | 60,0 | 70,0 | 6,3 | 7,4 | 9,0 | 13,0 | 25,0 | 13,0 | 100 | 71 | 46,0 |
| 3,5 | 33,0 | 40,0 | 55,0 | 78,0 | 93,0 | 8,5 | 10,0 | 12,0 | 18,0 | 33,0 | 18,0 | 123 | 85 | 62,0 |
| 4,0 | 43,0 | 52,0 | 70,0 | 100,0 | 120,0 | 11,0 | 13,3 | 16,0 | 23,0 | 42,0 | 23,0 | 150 | 100 | 82,0 |
| 4,5 | 55,0 | 67,0 | 90,0 | 130,0 | 160,0 | 14,0 | 21,0 | 26,0 | 37,0 | 55,0 | 37,0 | 190 | 120 | 103,0 |
| 5,0 | 67,0 | 82,0 | 110,0 | 160,0 | 190,0 | 18,0 | 29,0 | 36,0 | 52,0 | 67,0 | 52,0 | 220 | 140 | 127,0 |

Note
Notes

La perdita di carico nelle curve è soltanto quella dovuta alla contrazione dei filetti liquidi per cambiamento di direzione (lo sviluppo delle curve deve essere quindi compreso nella lunghezza della tubazione) mentre la perdita di carico nelle valvole e saracinesche è stata determinata in base a prove tecniche
 La perdita di carico per saracinesche e curve normali è pari a quella di 5 metri di tubazione diritta mentre per valvole di ritegno a clapet a 15 metri. I valori indicati si intendono per tubazione incrostante occorrerà considerare i corrispondenti aumenti.

The pressure drop in curves is only the one due to the contraction of the liquid thin thread for directional change (the development of the curves must be included in the length of the piping), while the pressure drop in the valves and gates is been determined on the basis of technical testes.
 The pressure drop for gates and normal curves is equal to 5 metres of straight piping, while for not return coplè valve is to 15 metre. The values indicated are intended for piping internally smooth. In case of overlaid piping, will need to consider the corresponding increase.